

ifm electronic



AS-Interface instead of complex wiring



Industrial communication
www.ifm.com/gb/as-i



Safe, easy, cost-optimised!



AS-Interface controllers / gateways



AS-Interface I/O modules



AS-Interface expansion



AS-Interface power supplies / earth fault monitors



AS-Interface AirBoxes for pneumatics



AS-Interface devices for valves and valve actuators



AS-Interface sensors

ifm electronic

The family-run medium-sized company has more than forty years of experience in automation technology. In addition to high quality standards and innovative products, the customers' needs are the focus of ifm's philosophy. The product portfolio embraces AS-i components for different areas: from packaging and conveying, silo applications, machine tools, robotics and automation, port and harbour logistics through to the food industry.



AS-Interface Safety at Work



Fieldbus components



IO-Link components

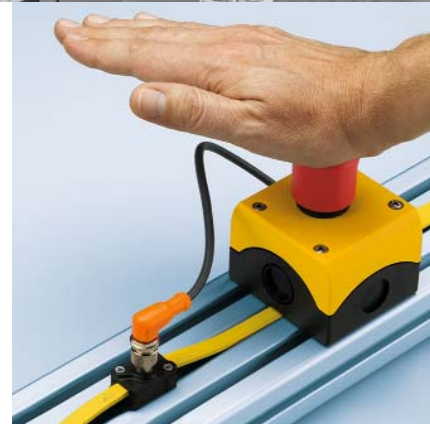

Reliable:
The sophisticated AS-i technology and the extended diagnostic possibilities provide high reliability and machine uptime.
"Safety at Work" is the AS-Interface expansion by safety-related components. Safety components up to the highest control category 4 to EN 954-1, SIL 3 to IEC 61508 and EN ISO 13849-1 / PL e can be connected to AS-i.



Just scan the QR code and watch a video on the test series of the AS-i products during production.

www.ifm.com/gb/asi-tests



AS-Interface from ifm electronic – ease of communication up to the highest level

Standardised:

The actuator-sensor interface (= AS-Interface) is a manufacturer-independent standard for connection of actuators and sensors of the first field level. ifm electronic provides you with your complete AS-i system solution.

Reliable:

The sophisticated AS-i technology ensures high reliability and machine uptime.

Simple:

Modular structure and flexible connection technology ensure easy integration into the AS-Interface system.

Cost-optimised:

A two-wire flat cable transmits data and energy, eliminating complex parallel wiring.



Cost-optimised:
Low wiring complexity due to two-wire cable. AS-i participants can be positioned in a decentralised way so that the control cabinets become smaller and less expensive. Furthermore, the possibility of expansion during set-up provides more flexibility.



Easy:
Due to the standardised system, the low wiring complexity and quick connection technology, AS-i enables simple "Plug & Play". The reduction of terminals leads to reduced documentation.

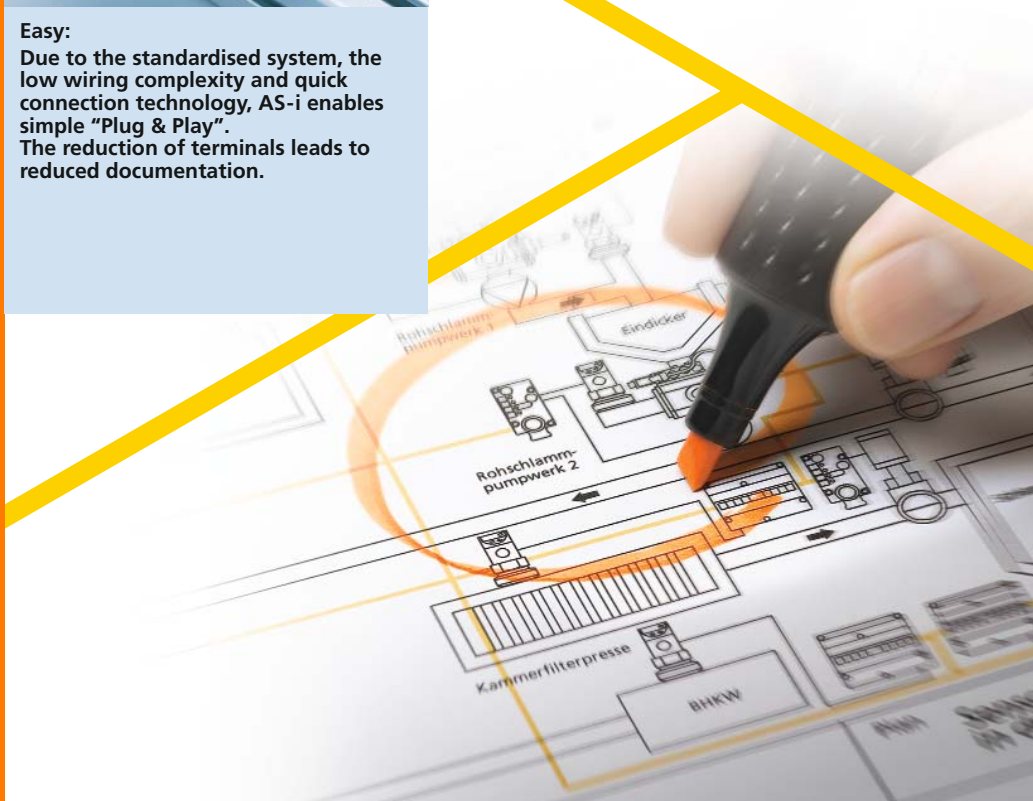

AS-Interface in the control cabinet

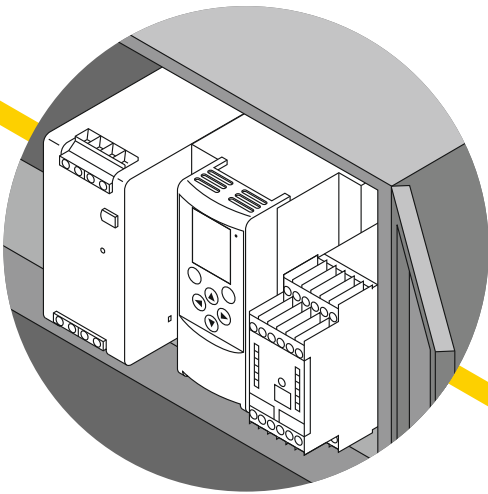

AS-i power supply

AS-i master

AS-i safety monitor

Only the central control components of the AS-i network are integrated into the control cabinet, well protected against external influences.



RFID in a packaging line.



Tidy control cabinet:
The central control components of the AS-i network.

The *master* assumes the most important function in each AS-i network. It handles the AS-i slaves and polls them cyclically. It also connects the AS-Interface to higher-level fieldbuses such as Profinet, Profibus, EtherNet/IP.

The *AS-i power supply* provides the required supply voltage and assumes the task of data coupling.

The *safety monitor* monitors all connected safety slaves and ensures the deactivation in case of a fault or the activation of the safety system.



For more information on the AS-i master just scan the QR code.

www.ifm.com/gb/master



For more information on power supplies just scan the QR code.

www.ifm.com/gb/power





AS-Interface in conveying and packaging

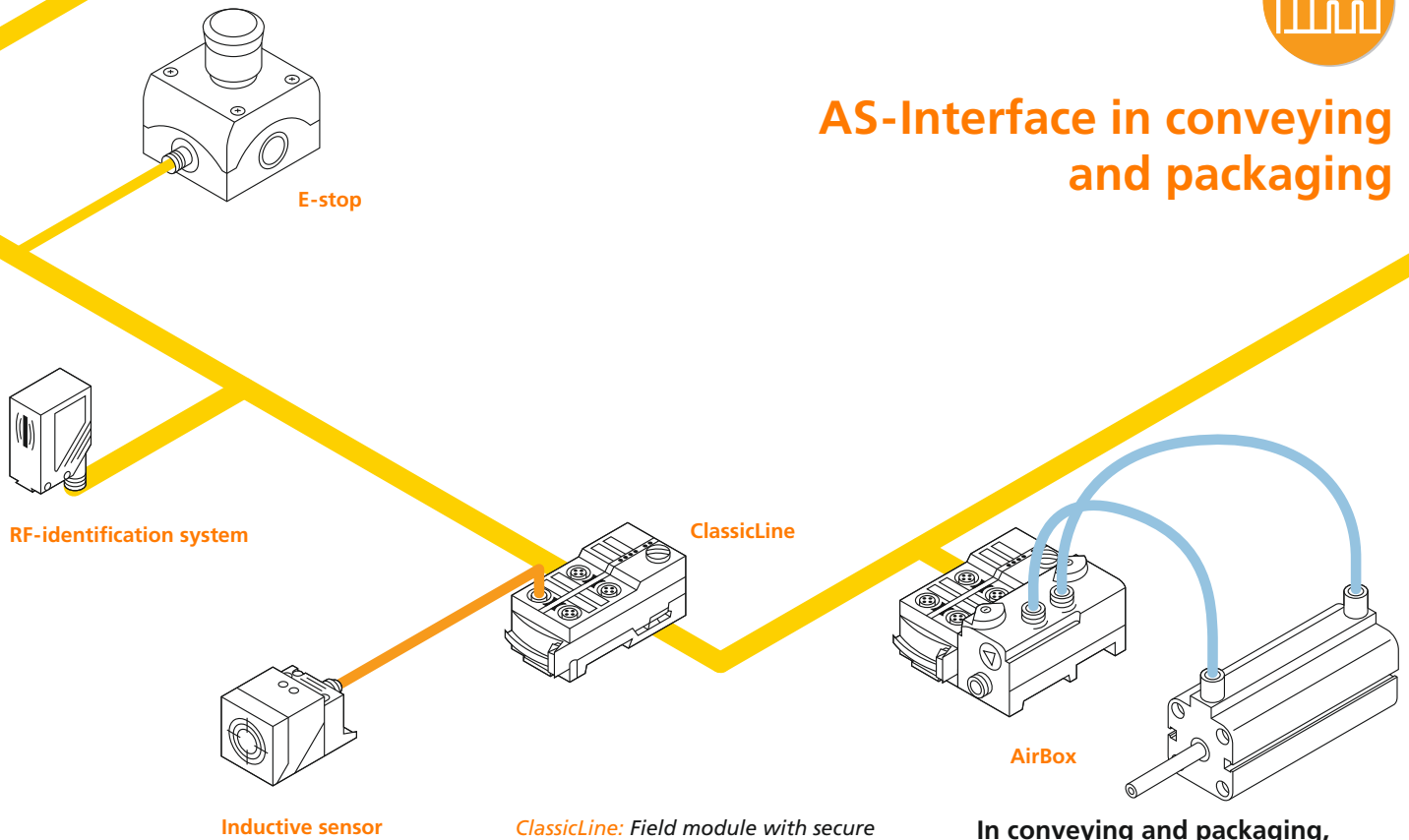

In conveying and packaging, drives can be directly controlled via AS-Interface.

ClassicLine: Field module with secure mounting and high protection rating, supporting the decentralised structure of AS-Interface.

AirBox: The pneumatic box can be mounted without tools and reduces energy costs as a result of its decentralised installation and short tube length.

RF-identification system: The special RFID system for ranges up to 100 mm.

E-stop, illuminated pushbutton module: Safety technology in the bus system: The controller receives a precise signal from the actuated slave.

Inductive sensors detect – reliably and without wear – metals at high switching frequencies and accuracy.

Connection technology: The ecolink M12 connector connects the sensors and actuators used to the field modules. It ensures maximum operational reliability due to its vibration protection with end stop.



Safety at Work: Here an e-stop is implemented with AS-Interface.



ClassicLine module in field application. Here it is integrated into a packaging machine.



DIN rail mounting without tools: Decentralised installation of a ClassicLine module.





Inductive sensors reliably detect the hatch position in a silo.

More information on slide valve control at:
www.ifm.com/gb/svc



Low-cost:
 Direct triggering of the cylinders by the AS-i AirBox.

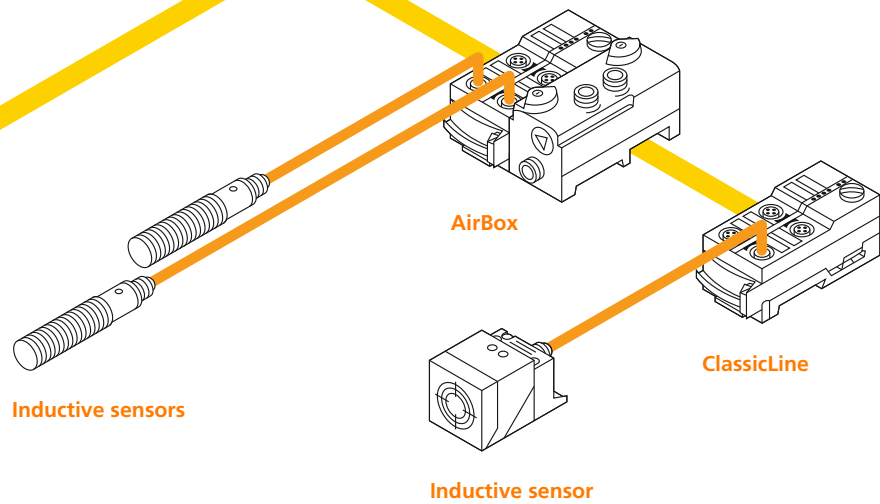

AS-Interface in the silo

In addition to the detection of the level and volume of these large tanks, the monitoring of the hatch position is another important aspect.

Inductive sensors, ideal for silo applications – large M18 designs, ATEX certified sensors and sensors in plastic housing.

Connection technology: The connectors of the ecolink EVCxxA series hold the EC type examination certificate by DEKRA EXAM. In accordance with the strict standard requirements, they are allowed for use in ATEX areas of the categories 2D, 3D and 3G.

ClassicLine: Using the ClassicLine module, the valves of a pneumatic cylinder can be triggered conventionally.

AirBox: The pneumatic box for hatch control in silos. It is the low-cost alternative to conventional valve control using cylinders.





AS-Interface in machine tools

High demands:
For use in machine tools and mobile machines, ifm electronic has developed special system components. These sensors and actuators are distinguished by increased shock and vibration resistance as well as high resistance to oily environments.

CompactLine: The field modules from the CompactLine series are distinguished by their high vibration and shock resistance.

Analogue modules of the CompactLine series ensure quick transmission times of max. 60 ms.

Fail-safe inductive sensor of the category 4 detects metal without contact and without a specific target.

E-stop: Safe e-stop with integrated AS-i slave.

SI flow sensor: This flow sensor in a robust stainless steel housing ensures a reliable monitoring of gases and liquids.

Inductive sensors for the machine tool industry – resistant to aggressive oils and coolants. Rectangular and cylindrical housings with thick walls.

Pressure transmitter: In addition to its compact and robust design, the AS-i compatible PPA pressure transmitter moreover features an analogue value display for the measured relative pressure.

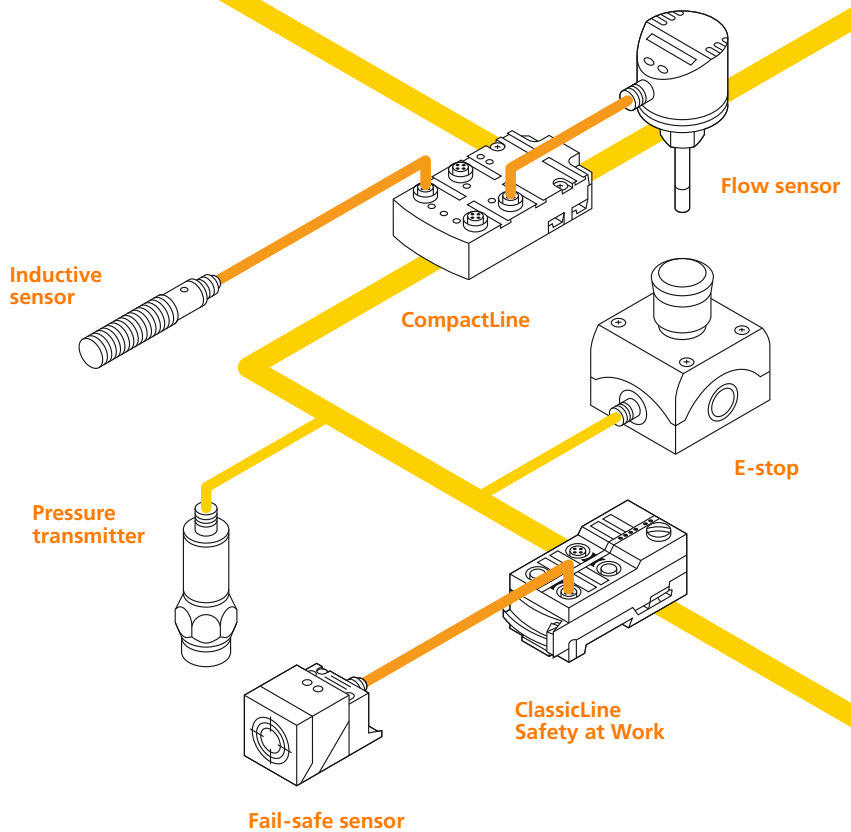

Connection technology: The oil-resistant ecolink EVC connector connects the sensors and actuators used to the field modules. It ensures maximum operational reliability due to its vibration protection with end stop.



Reliable detection without a specific target: ifm fail-safe inductive sensor.

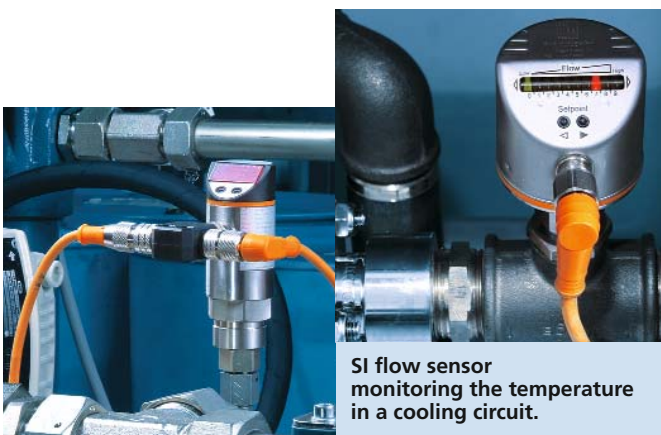

ifm pressure sensor on a hydraulic power unit.

SI flow sensor monitoring the temperature in a cooling circuit.



AS-Interface in robotics and automation

The handling system controls the material flow from or to the different processing stations. Especially here, the use of AS-Interface ensures a better overview of the wiring.

ClassicLine: The robust DIN rail mounting of the FC lower part and the innovative quick mounting technology facilitate the integration of the field module.

RF-identification system: Ingeniously simple – identification and coding with the RFID system from ifm electronic.

AirBox: Digital inputs, extended addressing mode and three freely selectable directions of the flat cable provide increased flexibility.

Cylinder sensors from ifm electronic detect the position of the pneumatic piston and transmit the signals directly to the AirBox.

AS-i M8 module: In their small design the modules provide digital M8 inputs and outputs.

Connection technology: The weld slag resistant ecolink EVW connector is suited for drag chains and torsional movements.

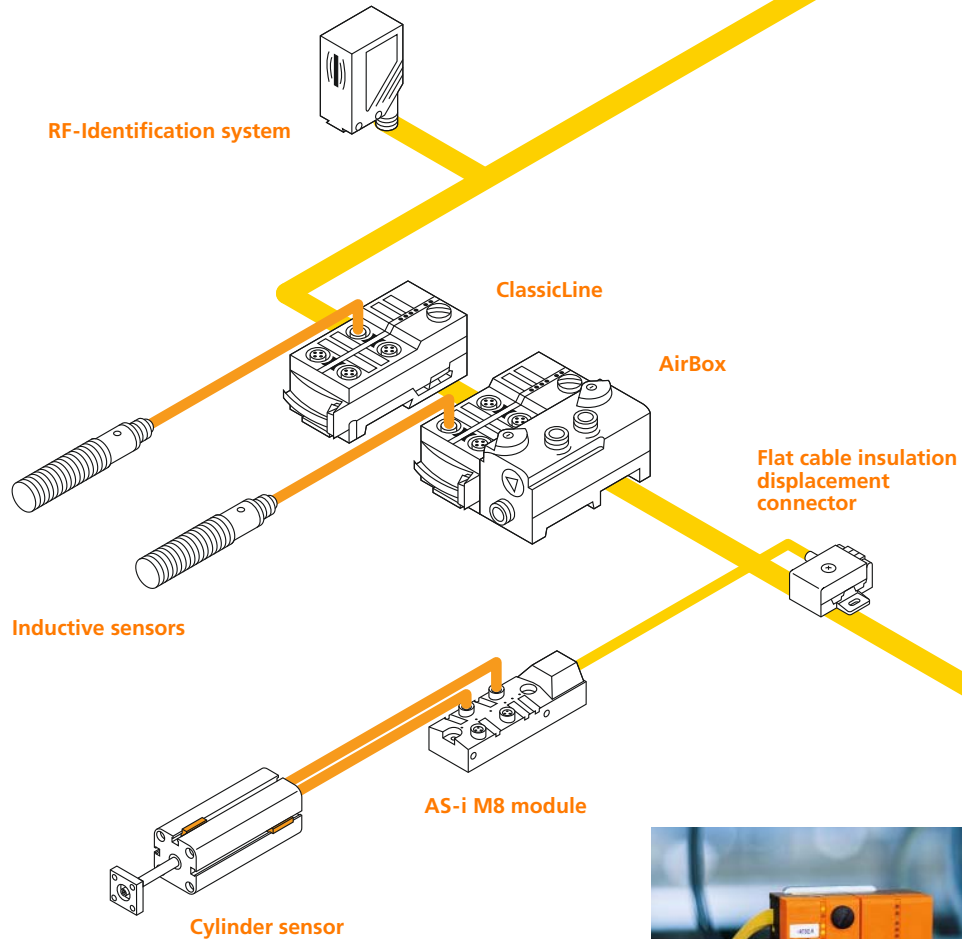

The RFID system codes and identifies workpiece carriers in a production line.



ClassicLine: Quickly and reliably ready for operation due to quick mounting technology.





AS-Interface in the control cabinet



Decentralised control cabinet:
Convenient and economic.

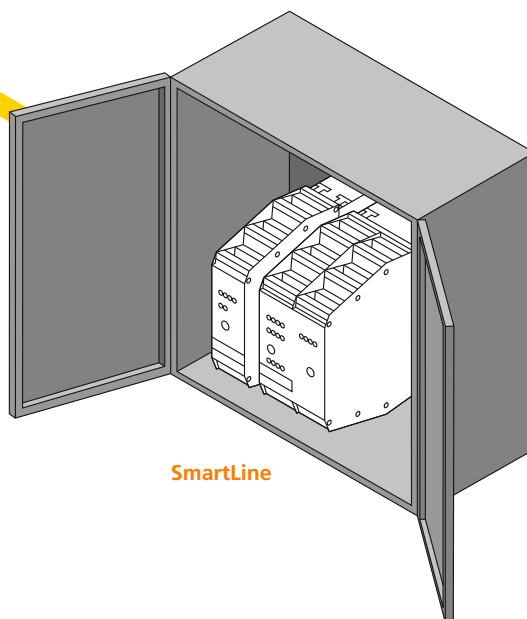

SmartLine

Small, decentralised modules can be integrated into the control box directly on site. So, the plant manufacturer can individually set up different plant sections.

SmartLine: Control cabinet modules with 25 or 50 mm width. The special advantage regarding space comes from the three-line arrangement of terminals.

PCB: The PCB AC2729 enables AS-i compatibility for all operating elements, the PCB AC015S even for e-stops.



ifm cylinder sensors:
Wear-free and with robust fixing.



Slim, flat AS-i M8 module with tried-and-tested ecolink technology.



Successful integration:
The PCB gives operating elements AS-i compatibility.



Operating element with AS-i compatibility in the automotive industry.

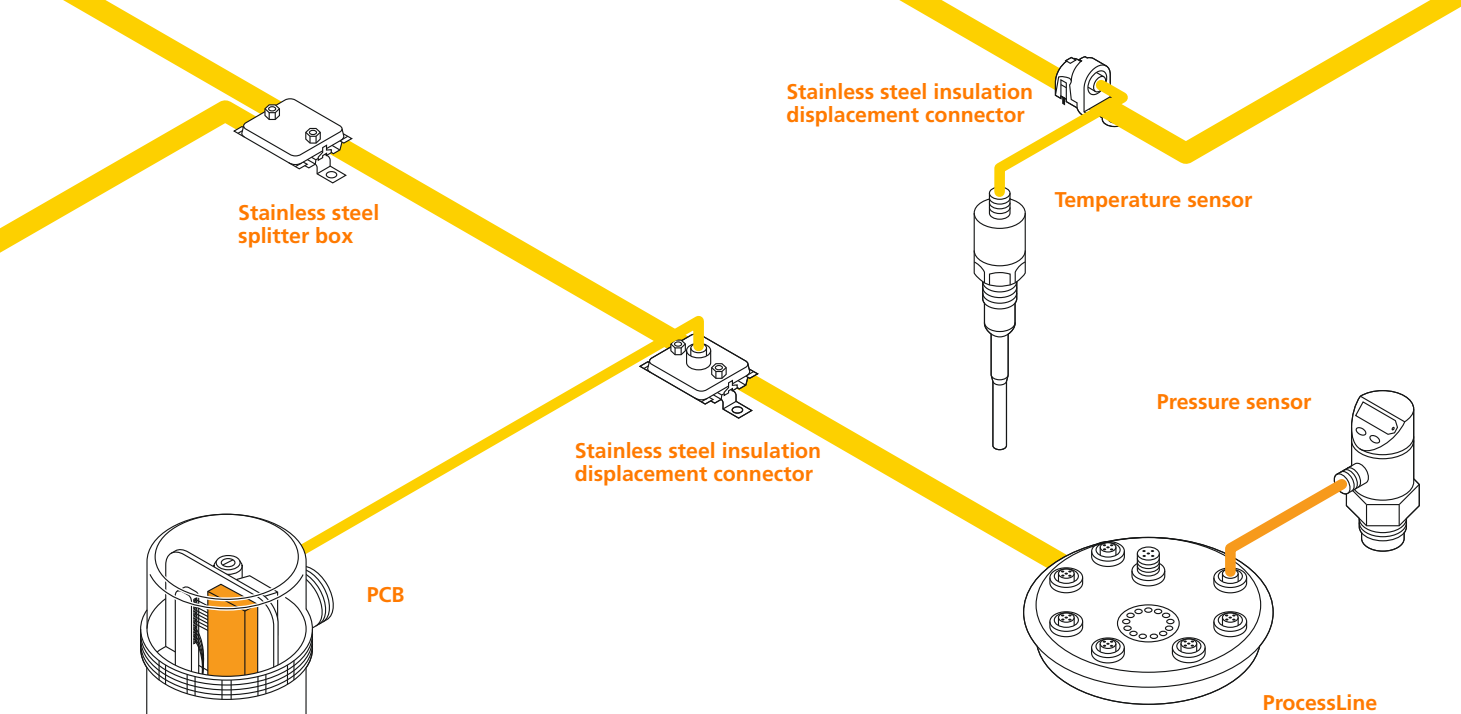

AS-Interface in the food industry

ifm electronic, one of the internationally leading sensor manufacturers, provides application solutions for all important areas of the food industry. The sensors are exposed to extreme conditions, including acids, alkalis, cleaning agents, foam guns, temperature shocks, high-pressure cleaners and high air humidity. Therefore the requirements on the wiring technology used are extremely high.

ProcessLine: The splitter boxes and field modules are specially tailored to the high demands in the food industry.

Stainless steel insulation displacement connector: ECOLAB certified flat cable insulation displacement connector with protection rating IP 68 / IP 69K for the connection of intelligent AS-i participants.

Stainless steel splitter boxes: Stainless steel flat cable splitter boxes distribute the AS-i voltage and/or the external 24 V supply.

TAA temperature sensor: Temperature transmitter with excellent response time, high mechanical stability and protection rating IP 69 K.

PCB: It makes valve tops AS-i compatible.

Pressure sensors: Special series for hygienic areas monitor for example the pressure in the food and beverage industries. They comply with the 3A, FDA and EHEDG requirements.

Connection technology: ecolink EVT is the optimum connector for hygienic and wet areas. High-quality PVC cables and housing materials, high-grade stainless steel nuts as well as the high protection rating IP 68 and IP 69K ensure ingress resistance between the sensor and the module.



ProcessLine: St. steel module with very high protection rating in a portioning system.



The temperature transmitter TAA monitors the system temperature in filtration.





AS-Interface in particularly harsh environments

Harsh environmental conditions place highest demands on the sensors used.

CompactLine: Due to the compact design and a fully potted housing the field modules withstand even the most adverse environmental conditions.

Hydraulic valves can also be switched via the 2 ampere output.

AS-i PPA type pressure sensors are equipped with a ceramic pressure measuring cell. The values for water or oil hydraulic pressure are measured directly in the medium.

Inductive sensor: The inductive IMC rectangular design with rotatable M12 connector and reinforced plastic housing is ideally suited for use in harsh environments.

Connection technology: From factory automation to the machine tool industry ecolink EVC ensures maximum operational reliability due to its vibration protection with end stop.



AS-i pressure sensors

CompactLine

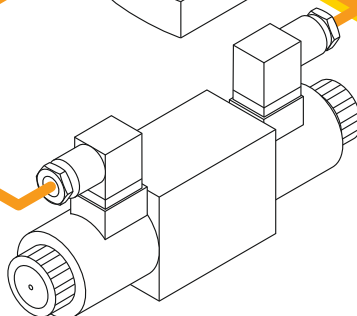
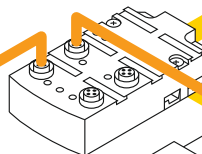

Pressure sensors of the type PPA with high shock and vibration resistance.

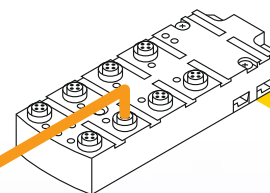

CompactLine

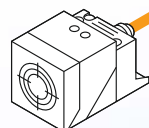

Inductive sensor



CompactLine:
Robust and compact fully potted field module.



CompactLine used in a hardening shop.



Visit our website:

www.ifm.com

Over 70 locations worldwide –
at a glance at www.ifm.com

ifm electronic gmbh
Friedrichstraße 1
45128 Essen
Tel. +49 / 201 / 24 22-0
Fax +49 / 201 / 24 22-1200
E-mail info@ifm.com



ifm electronic – close to you!

Overview
ifm product range:



Position sensors



**Sensors for
motion control**



Industrial imaging



Safety technology



Process sensors



**Industrial
communication**



Identification systems



**Condition monitoring
systems**



**Systems for
mobile machines**



**Connection
technology**



Accessories