



# User manual for the process industry

Solutions and components for your success

# Solutions and components for the process industry

Following the principle, „We connect the field to your control system“, Phoenix Contact offers you a comprehensive range of solutions and products for automation in process technology and process engineering.

Customized solutions from our forward-looking product portfolio make us a partner that you can depend on, wherever you are in the world.

## From the field to the control system – Always the right connection

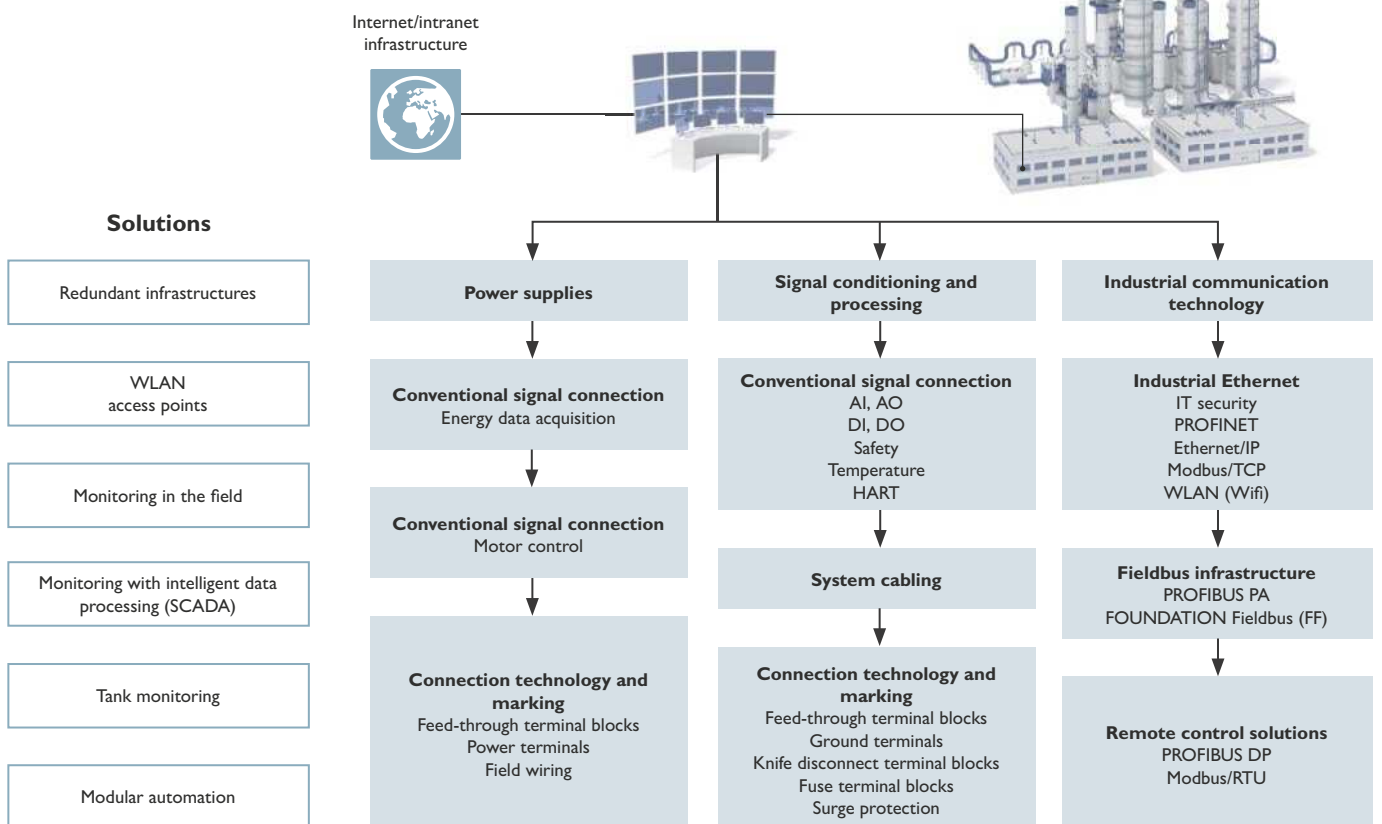



## Contents

---

Solutions for the process industry	4
Redundant infrastructures	6
WLAN access points	8
Monitoring in the field	10
Monitoring with intelligent data processing (SCADA)	12
Tank monitoring	14
Modular automation	16

---

Components for the process industry	
HMIs, PCs, and Industrial Ethernet	18
Power supplies	26
Connection technology and marking	34
Conventional signal connection	56
System cabling	84
Fieldbus infrastructure	98
Remote control solutions	106
Stainless steel empty enclosures	118

---

Index A–Z	122
-----------	-----

---

### Find out more with the web code

For detailed information, use the web codes provided in this brochure. Simply enter # and the four-digit number in the search field on our website.

 Web code: #1234 (example)

Or use the direct link:  
[phoenixcontact.net/webcode/#1234](https://phoenixcontact.net/webcode/#1234)

# Solutions for the process industry

Our range of solutions includes a diverse assortment of software and hardware components for achieving the greatest possible system availability.

These solutions enable reliable operation, secure remote access, and optimized maintenance through the monitoring of your systems.

We also offer technical solutions for retrofitting existing systems. These can be efficiently expanded by adding a communication infrastructure for acquiring signals. Previously unused data for optimizing your system is available to your control system.



## Redundant infrastructures

Redundant infrastructures are indispensable for maximum availability of your system. Phoenix Contact provides versatile solutions here for highly reliable operation.



## WLAN access points

Phoenix Contact provides solutions for wireless communication via WLAN access points up to Zone 2.



## Monitoring in the field

Monitoring system areas is often very expensive. It costs significantly less to transmit signals using reliable wireless transmission options instead of cables.



### Monitoring with intelligent data processing (SCADA)

In addition to data transmissions and the associated security aspects, preprocessing of the data is becoming ever more important.



### Tank monitoring

Phoenix Contact provides various solutions for monitoring tank farms, from simple fill level detection and valve position monitoring to overflow protection.



### Modular automation

Decentralized automated system parts enable higher adaptability of the system park and therefore a faster product launch.



# Redundant infrastructures

The process industry depends on having a particularly high level of system availability. Phoenix Contact provides you with a broad portfolio of solutions – from redundant network structures and secure power supplies to remote control solutions with high network security. We provide you with support from the planning phase right up to installation of the product.



## Your advantages

- ✓ Greater system availability is enabled by redundant infrastructures
- ✓ Maintenance is faster and simpler by integrating remote maintenance systems

# Product solutions for your success



## Industrial Ethernet and I/O systems

Reliable networks enable highly efficient system operation, thanks to high availability. Phoenix Contact offers you a wide range of solutions for a smooth process flow.

For more information, refer to page 18 ff., 60 ff.



## Power supply

Requirements-based power supplies form the foundation for long-lasting, uninterrupted system operation. Our sophisticated product portfolio supports you in these operations.

For more information, refer to page 26 ff.



## Remote control solutions

Phoenix Contact offers a comprehensive product range for interference-free data transmission in remote or wide-ranging networks and for worldwide system monitoring.

For more information, refer to page 106 ff.

## Solutions for reliable system operation

A high level of system availability is paramount to production processes. Phoenix Contact provides solution concepts here that are individually

matched to your needs, from redundant network infrastructures and network security to flexible remote control and remote maintenance solutions.

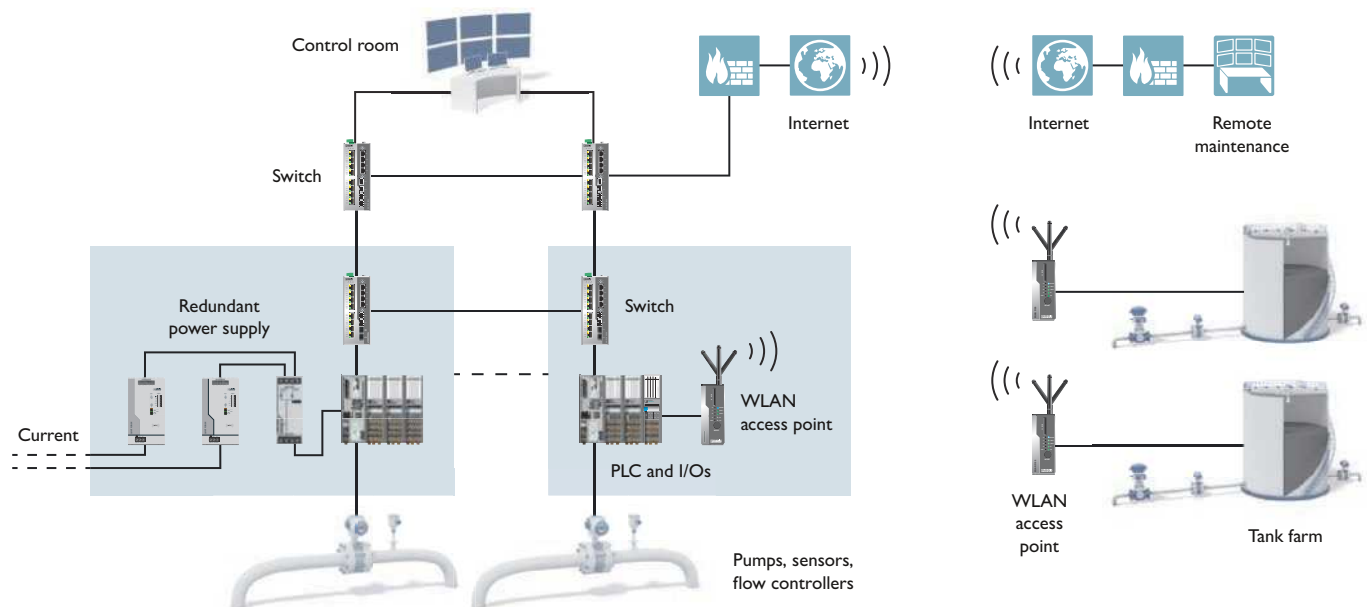

# WLAN access points

To ensure that the wireless Ethernet infrastructure can also be operated safely in potentially explosive areas, special protective measures are required. To this end, Phoenix Contact offers WLAN access points that are designed for operation in Zone 2. You can therefore benefit from the advantages of inexpensive and fast communication.



## Your advantages

- ✓ Extremely high security standard, thanks to encryption technology
- ✓ Ranges up to several hundred meters
- ✓ Suitable for indoor and outdoor use
- ✓ Easy installation and fast startup with intuitive planning and configuration concepts



# Product solutions for your success



## Patch panels

The patch panels serve as interface modules between the field and control cabinet cabling. Thanks to innovative connection technology, you have greater flexibility and time savings during installation.

For more information, see page 25.



## Industrial WLAN

Industrial WLAN is one of the key technologies for digitalization and represents outstanding performance and reliability. We provide you with the necessary products, solutions, and services for setting up reliable, wireless WLAN communication solutions.

For more information, see page 25.



## Control cabinet for the Ex area

The CLIPSAFE stainless steel enclosures provide comprehensive protection for your applications in industrial environments and in process technology areas. The customizable housings and their components are delivered with corresponding component approvals in accordance with ATEX and IECEx.

For more information, refer to page 118 ff.

## Easy WLAN networking in process plants

Digital maintenance and repair in process plants reduces costs and increases availability. An industrial wireless LAN infrastructure in the production plant is an essential requirement for keeping smart devices such as tablets connected to the production network at all times. In small and mid-size plants, the excessive

cost and complexity of IT WLAN systems is often a challenge. This is especially true if there is no trained IT staff to set them up and operate them. One simple alternative is central management of the WLAN network, which can be administered by the MCR/control engineering group itself. WLAN networks with up to 20 access

points can be easily integrated centrally using the web interface of a WLAN access point.

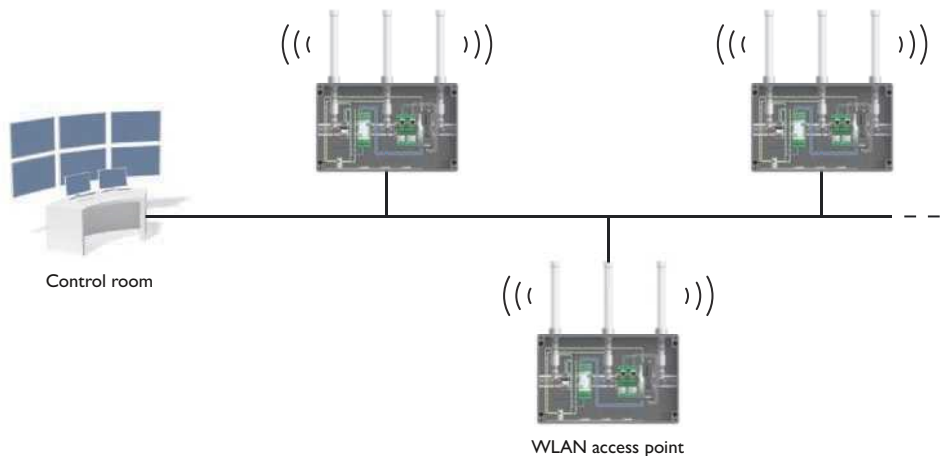

# Monitoring in the field

It is often expensive to monitor system areas in process technology systems due to the area they cover, since many meters of cables have to be routed using cable racks. This cost can be greatly reduced by using reliable wireless connections.

Potentially explosive areas can also be safely incorporated using permitted devices, such as our intrinsically safe I/Os in the Inline family.

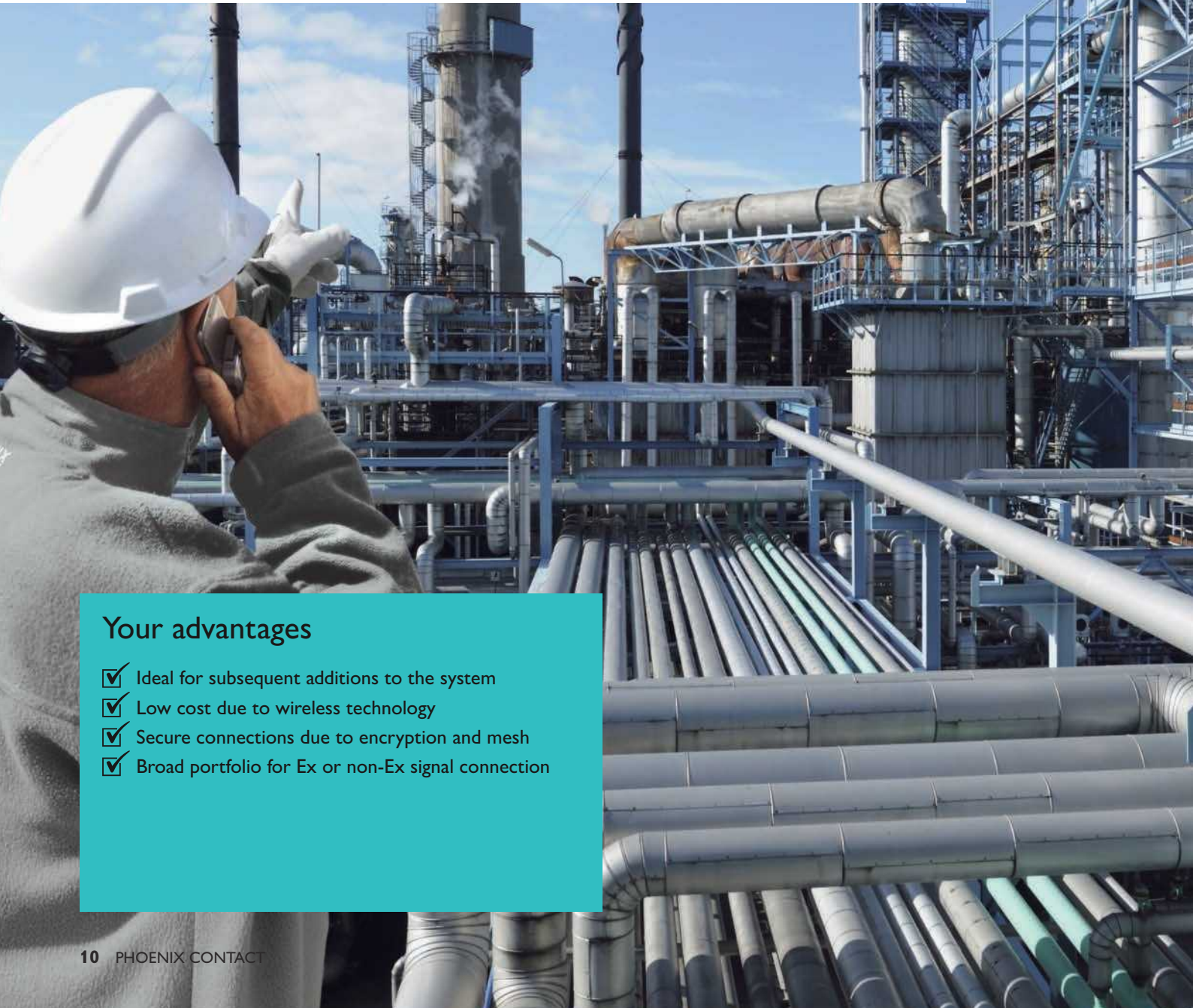

## Your advantages

- ✓ Ideal for subsequent additions to the system
- ✓ Low cost due to wireless technology
- ✓ Secure connections due to encryption and mesh
- ✓ Broad portfolio for Ex or non-Ex signal connection

# Product solutions for your success



## Radioline wireless system

Radioline is the wireless system for large systems. Inputs and outputs are easily assigned by simply turning the thumbwheel, without any programming. Thanks to Trusted Wireless 2.0 technology, Radioline is the ideal choice for reliable use in industrial environments.

For more information, refer to page 116 ff.



## Intrinsically safe I/Os

The intrinsically safe I/Os connect input and output signals to your network or bus system in potentially explosive areas.

For more information, refer to page 60 ff.



## Remote control solutions

Keep an eye on your system at all times: with the remote control solution from Phoenix Contact, you can monitor and control system parts that are in separate locations. This ensures that you are always kept informed about all the generic measured values of your remote stations. The control commands are sent directly from a central control room.

For more information, refer to page 106 ff.

## Signal connection via Radioline

The Radioline system has various wireless systems in accordance with the international standards, which means it can be used worldwide. A broad I/O portfolio rounds out the system. The wireless system is protected by an elaborate encryption process. To ensure high availability, the wireless system has a mesh network. TC Mobile, which can send feedback signals wirelessly, is an interesting alternative for simple systems.

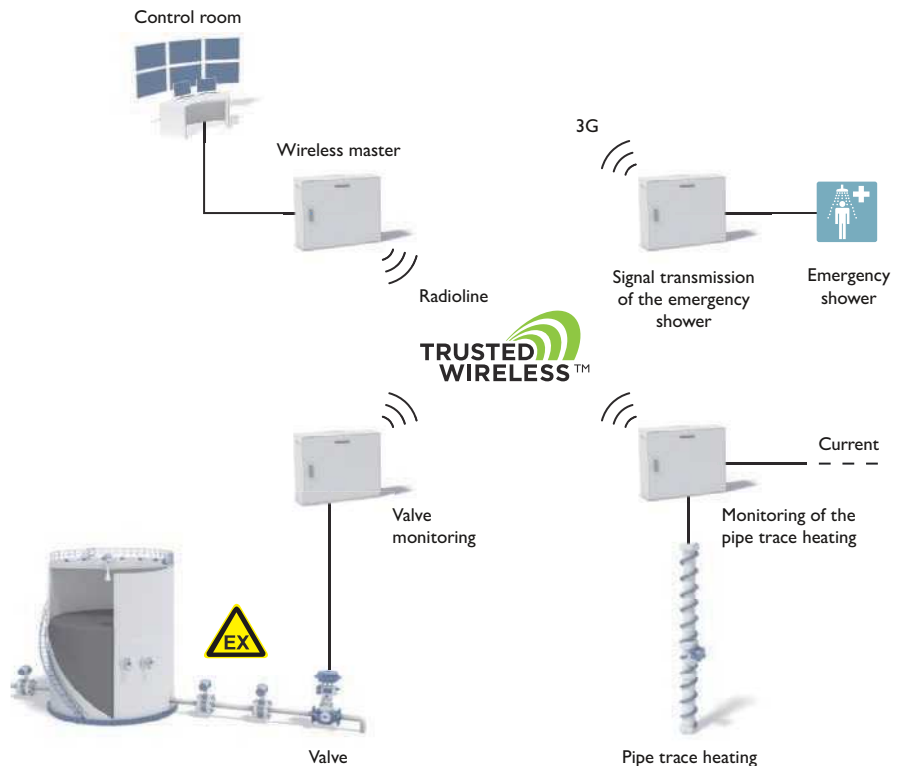

# Monitoring with intelligent data processing (SCADA)

System areas that are too far apart for connection by cable to be feasible are reliably connected through the Internet using VPN tunnels. Our security routers ensure that the tunnels are secure. They can communicate via cable or 3G/4G mobile phone technology. Small controllers in the field can provide the measurement data with precise time stamps or take over preprocessing of signals. The latest controller generation, with PLCnext Technology, can also easily save measurement data to our PROFICLOUD.

## Your advantages

- ✓ Worldwide connection of system areas
- ✓ Secure connections through the Internet using (additionally protected) VPN tunnels
- ✓ Current mobile phone technologies
- ✓ Optional cloud connectivity

# Product solutions for your success



## Open control platform

The high-performance PLCNext Control is the first controller to incorporate PLCnext Technology. Thanks to the open control platform, you can implement automation projects without the restrictions of proprietary systems. You work freely with your favorite programming languages and development tools.

More information can be found under:

**i** Web code: #1829



## Internet security

Monitoring solutions require a communication system, from the production department to company management. The entire network needs to have guaranteed sufficient protection against unauthorized access by people or malware. Phoenix Contact offers versatile products for this function.

For more information, see page 25.



## Remote control solutions

Phoenix Contact offers a comprehensive product range for interference-free data transmission in remote or wide-ranging networks and for worldwide system monitoring.

For more information, refer to page 106 ff.

## Secure remote communication

Our security routers in the mGuard product family have devices with a cable connection, an additional 3G/4G wireless connection, and a specific device for the process industry with ATEX, IECEx, and an expanded temperature range.

Our new controllers with PLCnext Technology also provide the option of easily saving data to the PROFICLOUD.

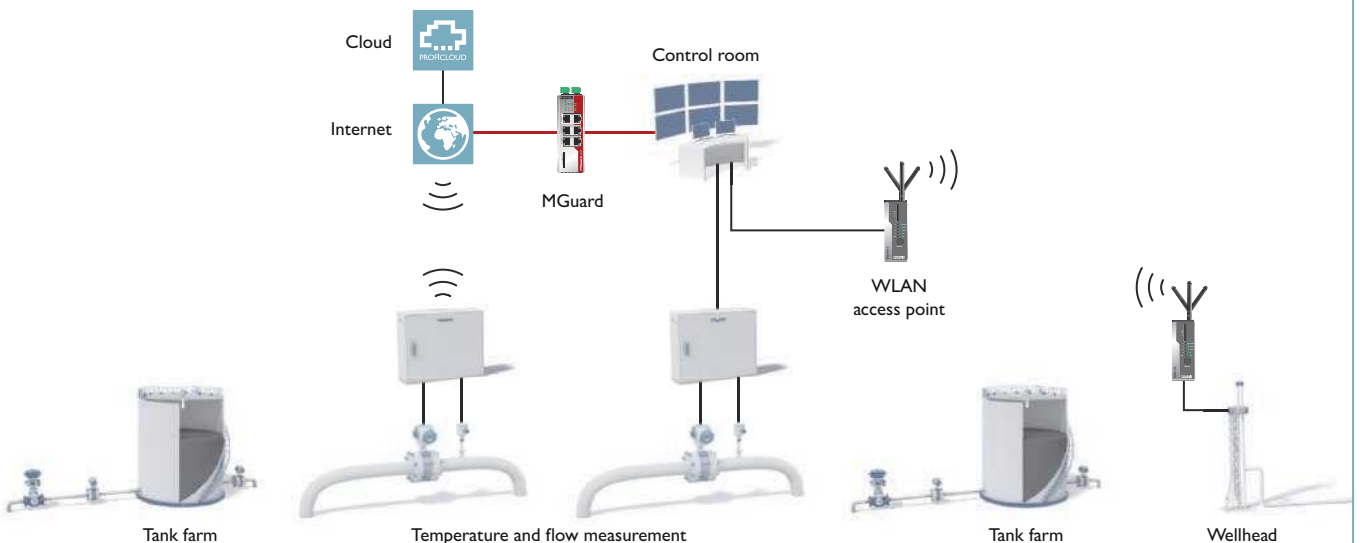

# Tank monitoring

Tank farms often consist of differently sized tanks, sometimes with a storage capacity of more than 30,000 m<sup>3</sup>. It is necessary to monitor the continuous filling and draining of the tanks and install reliable overflow protection. Automated valve position monitoring is essential here.

With reliable modular control and I/O systems, remote control and remote maintenance technology, as well as signal conditioners for the Ex area, Phoenix Contact provides a basis for the consistent automation of your storage tank systems.

## Your advantages

- ✓ Verified security with SIL-certified technology for overflow protection
- ✓ Standardized sensor communication with I/O technology in accordance with NAMUR
- ✓ One contact partner for tank and valve monitoring, thanks to industrial sector expertise
- ✓ Tested components with international Ex approvals



## Product solutions for your success



### Signal conditioners

The Ex i signal conditioners are suitable for signal connection in intrinsically safe circuits from all Ex zones to the distributed control system. These products are impressive not only because of their extensive range of approvals, but also because of their extremely small overall width.

For more information, refer to page 66 ff.



### PSRmini safety relay modules

Highly compact and extremely safe coupling relays provide electrical isolation and power adjustments in your process system. The modules adapted for the distributed control system are excellently suited for safe state off and fire and gas applications.

For more information, refer to page 58 ff.



### Surge protection

Phoenix Contact provides you with a wide variety of lightning protection zone solutions for surge protection. These are ideal for protecting a variety of infrastructure lines and for transmitters and receivers.

For more information, refer to page 62 ff.

## Complete solutions for automated tank farm management

You create efficient level control with an extensive portfolio of SIL-certified technology for functional safety, Ex i signal conditioners, and modular control systems. In parallel with the level control, overflow protection is installed to control a safety valve in the event of an emergency and stop the flow of the conveyed material immediately.

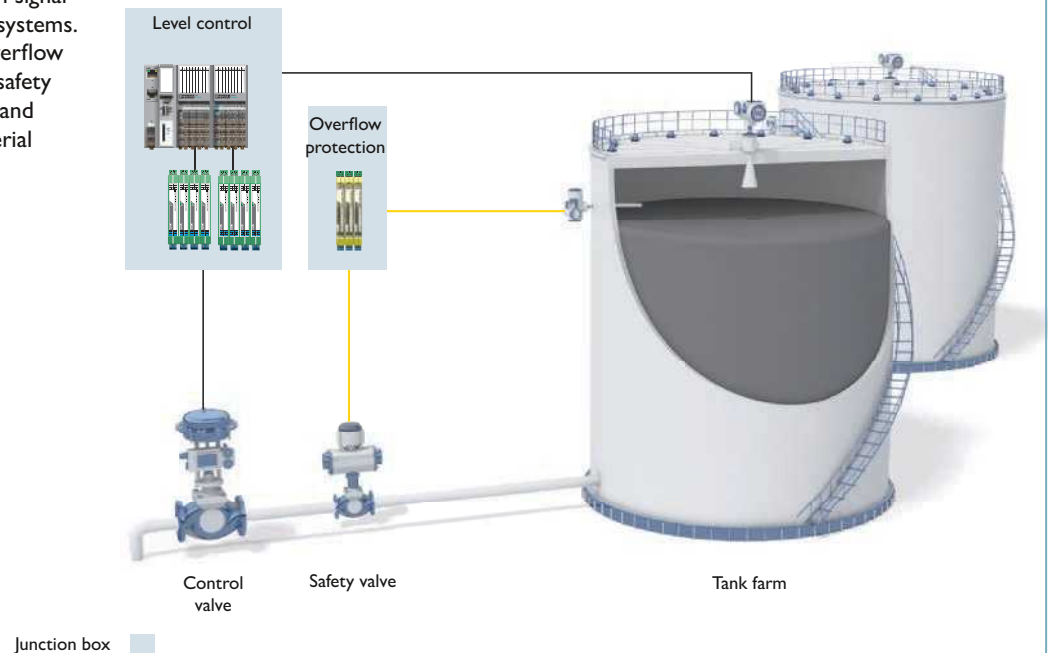

# Modular automation

The central topic of modular automation is time-to-market optimization through digitalization of systems and value added chains.

The NAMUR recommendation NE 148 describes a modular system, its modules, and a standard description with all of its functions that can be read by the higher-level engineering and control system.

The core process is centrally automated here, but secondary processes are already being provided by decentralized automated system parts.

## Your advantages

- ✓ Improved flexibility, efficiency, and profitability through reconfigurable, multipurpose production systems
- ✓ Reduced investment costs in tangible assets through reuse of modular components
- ✓ Easy maintenance through integration of remote maintenance systems



# Product solutions for your success



## Remote control solutions

The remote control solutions of Phoenix Contact enable you to easily integrate modules into a system network even when they are very far away. You will find suitable products for global networking of machines and systems, alarm generation, remote maintenance, and continuous data acquisition.

For more information, refer to page 106 ff.



## Industrial communication technology

Automation modules are securely networked using industrial communication technology from Phoenix Contact. We offer a comprehensive range of high-performance interface devices that meet the high demands of modern applications.

For more information, refer to page 18 ff.



## HART components

The HART product portfolio of Phoenix Contact provides you with expertise in Ethernet, Modbus/TCP/IP, PROFINET, wireless, and HART protocol technologies. Accordingly, each automation module has a component of the NOA concept (NAMUR Open Architecture).

For additional information, refer to page 76 ff.

## Solutions for modular systems

A high degree of system modularity is paramount to production processes in the chemical and pharmaceutical industry.

Phoenix Contact provides solution concepts here that are individually matched to your needs, from the automation of individual modules to the networking of these modules and transfer of their data to the distributed control system. Driver and interface solutions play an important role here in coupling automation solutions and I/O systems to other systems.

**i** Web code: #0894

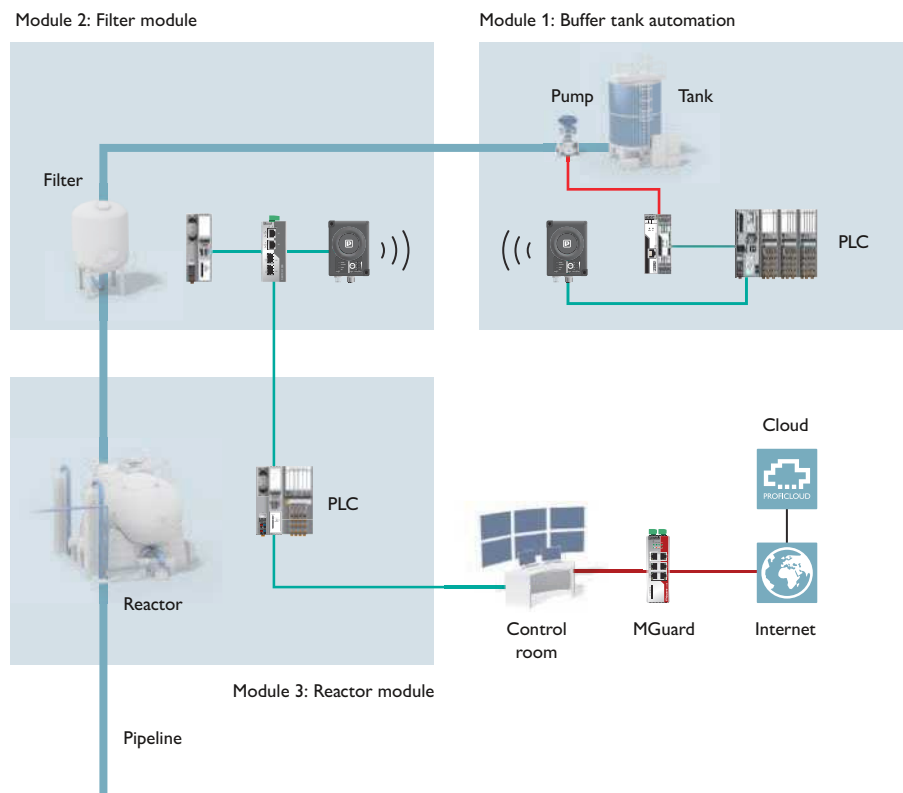

# Industrial Ethernet for consistent and productive communication

In order to make informed decisions, you need all the relevant information at your fingertips. This necessitates a company-wide uniform communication system, from the production department to company management. Furthermore, it has never been more important to ensure that you have adequate protection against unauthorized access by people or malware across the entire network. Phoenix Contact provides an infrastructure suitable for industrial applications and with the required approvals for the demanding requirements of the process industry.



## Industrial PCs

The robust box and panel PCs were specially developed for use in potentially explosive environments.



## Automation switches

Our powerful Managed Switches combine IT functions with fast redundancy and realtime properties. This ensures that you can guarantee reliable operation of your systems.



## Wireless solutions

The WLAN and Bluetooth wireless modules ensure reliable communication even under harsh conditions and are optimized for fast and stable PROFINET and EtherNet/IP™ transmission.

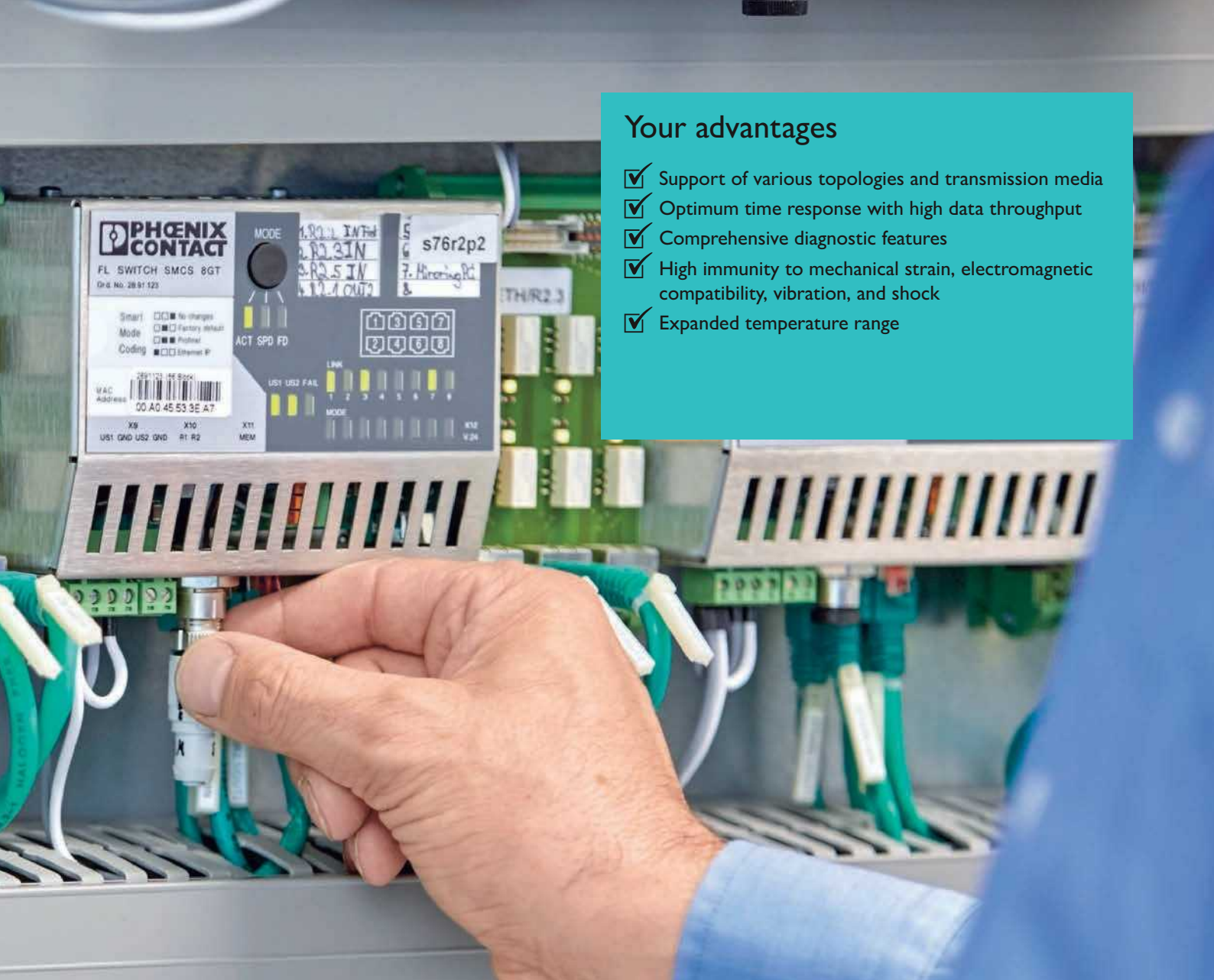

## Your advantages

- ✓ Support of various topologies and transmission media
- ✓ Optimum time response with high data throughput
- ✓ Comprehensive diagnostic features
- ✓ High immunity to mechanical strain, electromagnetic compatibility, vibration, and shock
- ✓ Expanded temperature range



### Modern firewalls

Security products in the mGuard range protect your systems against unauthorized access by people or malware. Furthermore, the VPN-capable devices enable secure remote maintenance.



### Surge protection

DATATRAB provides maximum protection against overvoltages at the highest transmission speeds. The various versions are system-compliant and equipped with the appropriate connection technology.



### Accessories

In addition to pre-assembled cabling systems, the comprehensive range of Ethernet accessories includes tools, software, and patch panels in various versions.

# HMI and industrial PCs

## Operating devices for Zone 2

Wherever liquids, gases, or powders are mixed, analyzed, or crushed, there is a need for operating and monitoring devices designed for these potentially explosive areas.

Our industrial PCs with IECEx and ATEX Zone 2/22 approvals have been specially designed for this use.

The box and panel PCs for potentially explosive areas are available in various performance classes.

The robust panel PCs are equipped with wide-screen displays with PCAP touch technology.

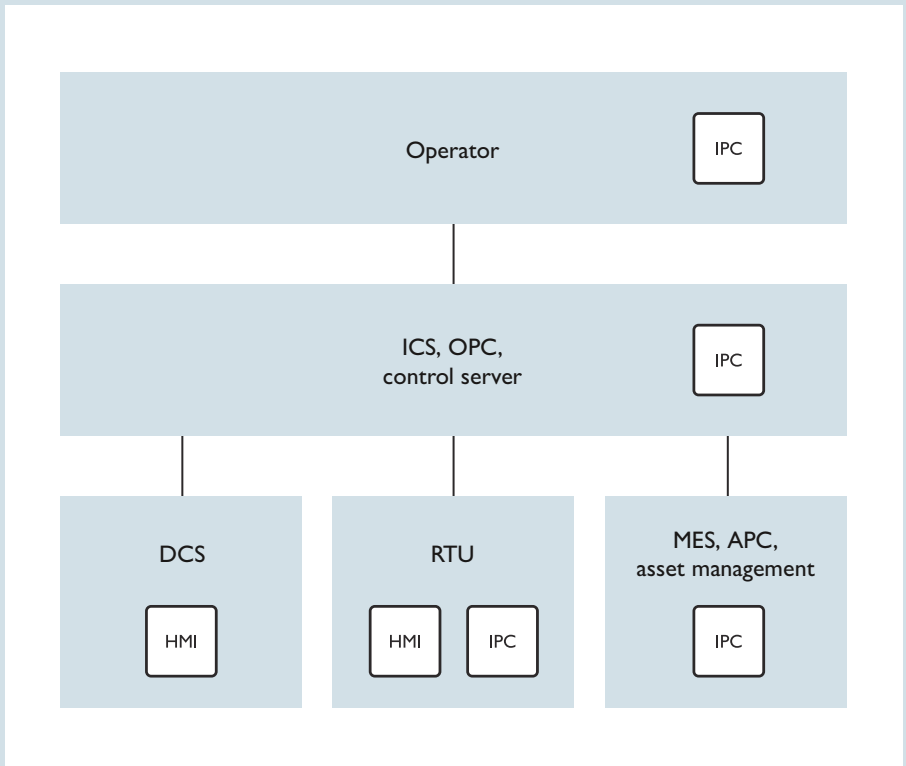

## Developed for use in potentially explosive areas

Our devices have all the required approvals that permit use in potentially explosive environments around the globe:

- UL C1D2 for use in North America
- ATEX for use throughout Europe
- IECEx for applications in potentially explosive environments around the globe

**i** Web code: #1999









**Multitouch**  
With a projected-capacitive touchscreen (PCAP) for multipoint operation

**High system availability**  
Fanless design and no moving parts







**Processor performance suited to the application**  
Optimum performance suited to every application, thanks to Intel® Atom™ and Core™ processors



## Panel PCs

 Web code: #2000  					
	Type Order No.	VL2 PPC 1000 EX 1050366	VL2 PPC 2000 EX 1050367	VL2 PPC 3000 EX 1050368	VL2 PPC 7000 EX 1050365
Touch technology	Projective-capacitive, ten-touch control				
Display size	17.8 (7") / 22.9 (9") / 30.7 (12.1") / 39.6 cm (15.6") / 47 cm (18.5") / 54.6 cm (21.5")				
Resolution (W x H)	800 x 480 (WVGA) / 1280 x 800 (WXGA) / 1366 x 768 (HD) / 1920 x 1080 pixels (Full HD)				
Processor	Intel® Atom™ E3845 4 x 1.91 GHz (quad-core)	Intel® Celeron® N2930 1.83 GHz (quad-core)	Intel® Core™ i3-4010U 1.7 GHz (dual-core)	Intel® Core™ i5-4300U 1.90 GHz (dual-core)	Intel® Core™ i7-6822EQ 2 GHz (quad-core)
RAM (configurable)	Max. 4 GB DDR3	Max. 8 GB DDR3	Max. 16 GB DDR3		Max. 16 GB DDR4
Data memory	HDD or SSD (configurable)				
Temperature range Operation with HDD: With SSD: Storage:	0°C ... +45°C 0°C ... +50°C -25°C ... +70°C	0°C ... +45°C -20°C ... +60°C -40°C ... +70°C	0°C ... +45°C -10°C ... +60°C -40°C ... +70°C	0°C ... +45°C -10°C ... +60°C -40°C ... +70°C	0°C ... +45°C -20°C ... +60°C -40°C ... +70°C
Degree of protection	IP65 (front) / IP30 (back)				
Approvals	ATEX, IECEx, UL				

## Box PCs

 Web code: #2001  					
	Type Order No.	VL2 BPC 1000 EX 1054028	VL2 BPC 2000 EX 1054027	VL2 BPC 3000 EX 1054025	VL2 BPC 7000 EX 1054024
Processor	Intel® Atom™ E3845 1.91 GHz (quad-core)	Intel® Celeron® N2930 1.83 GHz (quad-core)	Intel® Core™ i3-4010U 1.7 GHz (dual-core)	Intel® Core™ i5-4300U 1.90 GHz (dual-core)	Intel® Core™ i7-6822EQ 2 GHz (quad-core)
RAM (configurable)	Max. 4 GB DDR3	Max. 8 GB DDR3	Max. 16 GB DDR3		Max. 16 GB DDR4
Data memory (configurable)	SD, HDD or SSD	HDD or SSD			
Interfaces	1x COM (RS-232/422/485), optional: 1x COM (RS-232) + 1x COM (RS-485), 2x CAN 1 x DisplayPort 2x (10/100/1000 Mbps), RJ45	1x COM (RS-232/422/485), optional: 2x COM (RS-232) + 1x COM (RS-232/422/485) 2x DisplayPort 2x (10/100/1000 Mbps), RJ45			
Temperature range Operation with HDD: With SSD: Storage:	0°C ... +45°C 0°C ... +50°C -25°C ... +70°C	0°C ... +45°C -20°C ... +65°C -40°C ... +70°C	0°C ... +45°C -20°C ... +65°C -40°C ... +70°C	0°C ... +45°C -10°C ... +65°C -40°C ... +70°C	0°C ... +45°C -20°C ... +60°C -40°C ... +70°C
Degree of protection	IP30 (front/back)				
Approvals	ATEX, IECEx, UL				

Detailed information and additional approvals can be found at: [phoenixcontact.com/products](http://phoenixcontact.com/products)

# Network components for Industrial Ethernet

## High-performance, reliable networks

Ethernet switches allow a variety of end devices to be connected to the industrial network and, moreover, ensure the communication between them. Phoenix Contact offers an expansive portfolio for any application, from simple Unmanaged Switches for the field level up to high-performance Managed Switches for the process control level and connection to the office level. Integrated redundancy mechanisms here ensure a high level of failsafe performance for your system. Cyber security components with an integrated firewall and functions for secure remote maintenance enable users to set up secure system networks in accordance with IEC 62443 and ISA-99. For additional protection against damage caused by lightning strikes or switching operations, Phoenix Contact offers reliable surge protection for Ethernet cables.

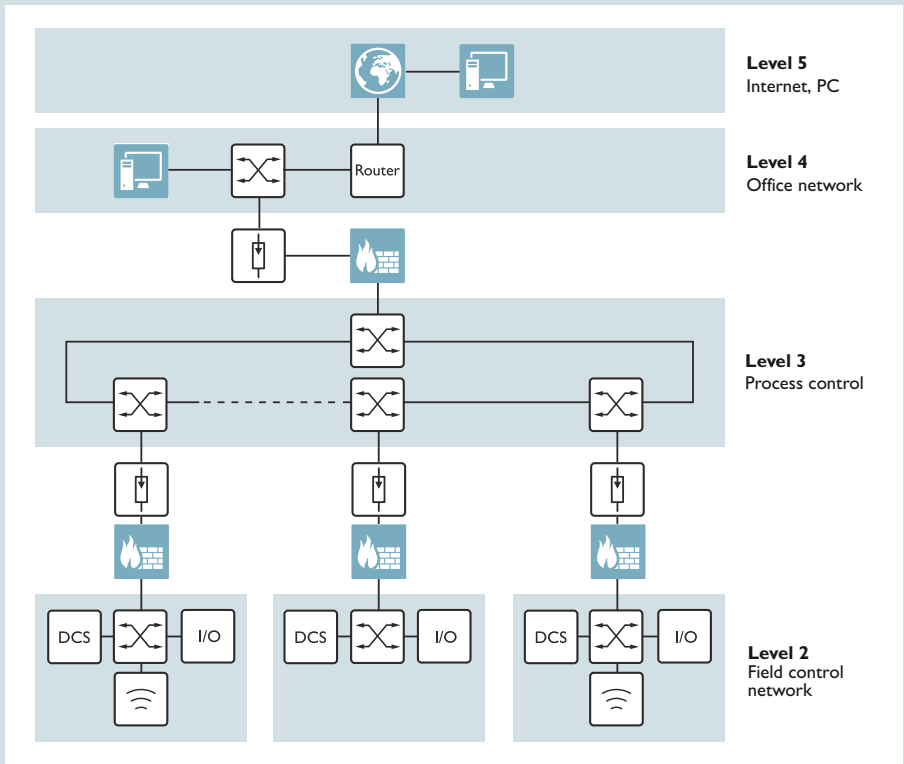

## Network security increases process availability









Due to the Ethernet-based connection of distributed control networks to the IT level, protecting the entire system against malware is vital. The mGuard firewall/router solution provides optimum protection for the control engineering. Furthermore, secure VPN connections enable effective

remote maintenance of the distributed control system over the Internet. The functions of the configurable Managed Switches also improve security. Mechanisms for disabling unused ports or restricting communication with end devices based







on the MAC address reduce the risk of unauthorized local access to the network.



## Ethernet switches

		 	 	 
		<b>Unmanaged Switches</b>	<b>Universal Managed Switches in the narrow design</b>	<b>Universal Managed Switches in the flat design</b>
Type	Order No.	FL SWITCH... ... SFNT 5TX <a href="#">2891003</a> ... SFNT 4TX/FX <a href="#">2891004</a> ... SFNT 8TX <a href="#">2891005</a> ... SFNT 7TX/FX <a href="#">2891006</a> ... SFNT 16TX <a href="#">2891952</a> ... SFNT 7TX/FX ST <a href="#">2891007</a> ... SFNT 14TX/2FX <sup>1</sup> <a href="#">2891954</a>	FL SWITCH... ... 2205 <a href="#">2702326</a> ... 2208 <a href="#">2702327</a> ... 2207-FX <a href="#">2702328</a> ... 2206-2FX SM <a href="#">2702331</a> ... 2206-2SFX <a href="#">2702969</a> ... 2306-2SFP <a href="#">2702970</a> ... 2316 <a href="#">2702909</a>	FL SWITCH... ... SMCS 8TX <a href="#">2989226</a> ... SMCS 8GT <a href="#">2891123</a> ... SMCS 6TX/2SFP <sup>1</sup> <a href="#">2989323</a> ... SMCS 6GT/2SFP <a href="#">2891479</a>
		 Web code: <a href="#">#1573</a>	 Web code: <a href="#">#1574</a>	 Web code: <a href="#">#1574</a>
Approvals		ATEX, IECEx, GL, UL <sup>1</sup> ATEX, IECEx, UL	ATEX, IECEx, GL, UL	ATEX, GL <sup>1</sup> ATEX
Ports		5/8/16	5/8/16	8
Port speed		10/100/000 Mbps	10/100/1000 Mbps	10/100/1000 Mbps
Filter functions		Quality of Service (QoS)*	Quality of Service (QoS)*, VLAN, Multicast/IGMP snooping	
Redundancy functions		–	RSTP, FRD, Large Tree Support, MRP (manager/client)	
Management functions		–	ACD, port configuration, statistics and utilization, DHCP server, LLDP, CLI, PROFINET device	ACD, port configuration, statistics and utilization, LLDP

## Ethernet switches

		 	 
		<b>Managed Industrial IT Switches</b>	<b>Managed Switches optimized for EtherNet/IP</b>
Type	Order No.	FL SWITCH 3008T <a href="#">2891035</a> FL SWITCH 3004T-FX <a href="#">2891033</a> FL SWITCH 3006T-2FX <a href="#">2891036</a> FL SWITCH 3006T-2FX ST <a href="#">2891037</a> FL SWITCH 3006T-2FX SM <a href="#">2891060</a> FL SWITCH 4012T-2GT-2FX <a href="#">2891063</a>	FL SWITCH 7008-EIP <a href="#">2701418</a> FL SWITCH 7006/2FX-EIP <a href="#">2701419</a> FL SWITCH 7005/FX-2FXSM-EIP <a href="#">2701420</a> FL SWITCH 7006-2GC-EIP <a href="#">2701554</a> FL SWITCH 7004-4GC-EIP <a href="#">2701553</a> FL SWITCH 7004-2TC-2GC-EIP <a href="#">2702175</a>
		 Web code: <a href="#">#1574</a>	 Web code: <a href="#">#1574</a>
Approvals		ATEX, IECEx, UL	UL
Ports		5 ... 16	8
Port speed		10/100/1000 Mbps	10/100/1000* Mbps
Filter functions		Quality of Service (QoS)*, VLAN, Multicast/IGMP snooping	
Redundancy functions		RSTP, ERR (15 ms)	DLR, RSTP, FRD, Large Tree Support
Management functions		Port configuration, statistics and utilization, LLDP	ACD, port configuration, statistics and utilization, DHCP server, CIP

\* Only available is selected models.

Detailed information and additional approvals can be found at: [phoenixcontact.com/products](http://phoenixcontact.com/products)





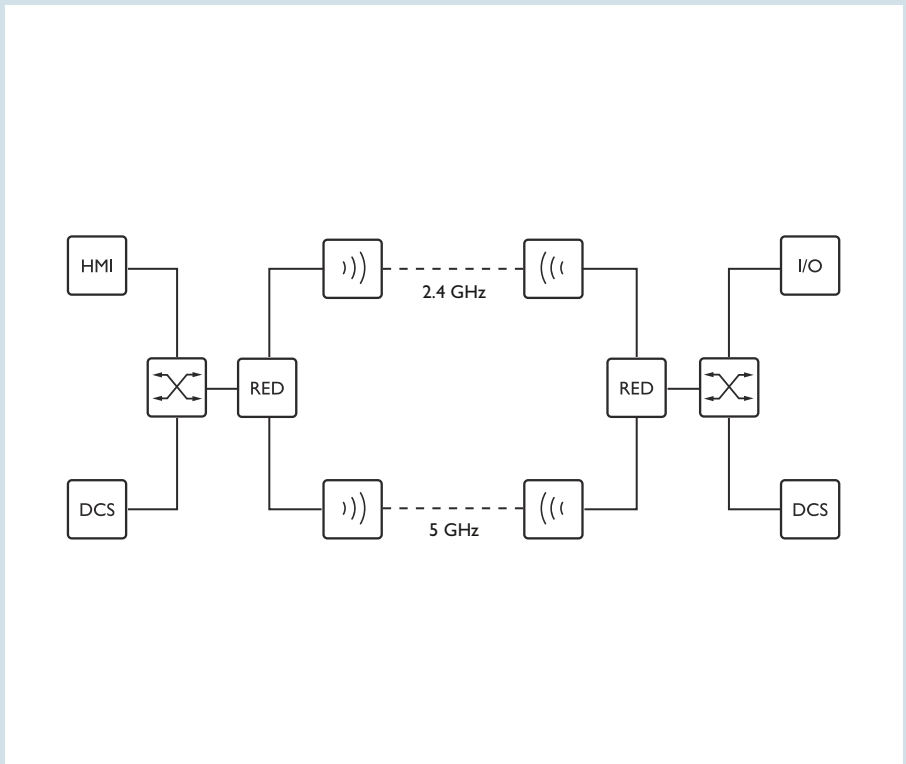

# Network components for Industrial Ethernet

## High-availability networks

Using the parallel redundancy protocol (PRP) provides a highly failsafe network. PRP network redundancy is based on two independent, active network paths between two devices. The transmitter uses two independent network interfaces that both send out the same data simultaneously. The redundancy control protocol therefore makes sure that the recipient only uses one data packet and discards the second. If just one data packet is received due to a fault, the recipient knows that a failure has occurred on the other path. However, communication is maintained, thanks to the second network path. You can also use PRP in combination with WLAN technology. This is especially useful in hard-to-reach places or on moving parts.









## Converter







				
		Ethernet gateways	Media converters	Surge protection
Type	Order No.	FL COMSERVER... ...BASIC 232/422/485 <a href="#">2313478</a> ...BAS 232/422/485-T <a href="#">2904681</a> ...UNI 232/422/485 <a href="#">2313452</a> ...UNI 232/422/485-T <a href="#">2904817</a> ...PRO 232/422/485 <a href="#">2313465</a>	FL MC... ...EF 1300 MM SC <a href="#">2902853</a> ...EF 1300 MM ST <a href="#">2902854</a> ...EF 1300 SM SC <a href="#">2902856</a> ...EF WDM-A SC <a href="#">2902658</a> ...EF WDM-B SC <a href="#">2902659</a> ...10/100BASE-T/FO-660 <a href="#">2708193</a>	DT-LAN-CAT.6+ <sup>1</sup> <a href="#">2881007</a> D-LAN-19"-24 <sup>2</sup> <a href="#">2838791</a> D-LAN-19"-16 <sup>2</sup> <a href="#">2880147</a> D-LAN-19"-8 <sup>2</sup> <a href="#">2880163</a> PLT-SEC-T3-120-FM-UT <a href="#">2907918</a> PLT-SEC-T3-120-FM-PT <a href="#">2907927</a> PLT-SEC-T3-230-FM-UT <a href="#">2907919</a> PLT-SEC-T3-230-FM-PT <a href="#">2907928</a>
		 Web code: <a href="#">#1577</a>	 Web code: <a href="#">#1578</a>	 Web code: <a href="#">#0145</a>
Approvals		ATEX	ATEX	GL, SIL, UL <sup>1</sup> GL, UL <sup>2</sup> No specific approvals



## Security router and WLAN access points

						
	<b>Security router</b>		<b>WLAN access points</b>			
Type	Order No.	FL MGUARD RS4000 TX/TX-P Software for installation on the PC: FL MGUARD SECURE VPN CLIENT LIC Appropriate commissioning software: FL MGUARD DM UNLIMITED	2702259 2702579 2981974	FL WLAN 5110 1043193 FL WLAN 5111 1043201	FL WLAN 2100 2702535 FL WLAN 2101 2702540	OGL-SC- WLAN-5100- EX-2 2403109
		 Web code: #1270	 Web code: #1532			
Approvals		ATEX, IECEx, GL, UL	–	–	ATEX	
Number of ports		2 x RJ45	1 x RJ45		2 x RJ45	
Data throughput		200 Mbps	300 Mbps			
Frequency band		–	2.4 GHz/5 GHz			
Security functions		Firewall functions, DPI (Deep Package Inspection) for OPC Classic and NAT (Network Address Translation)	The latest WLAN security standards, hardware-based AES encryption, user-defined passwords and access filters			
Special features		–	Two external antennas	Extra-robust, two integrated antennas	Built for ATEX Zone 2 (ATEX Ex II 3G)	

## Installation material

				
				
	<b>Patch cable and RJ45 connector</b>	<b>Ethernet patch panels</b>	<b>PRP redundancy module</b>	
Type	Order No.	Patch cable: NBC-R4AC1/1,0-94G/R4AC1-BU (1 m) 1413160 NBC-R4AC1/2,0-94G/R4AC1-BU (2 m) 1413161 NBC-R4AC1/3,0-94G/R4AC1-BU (3 m) 1413162  RJ45 connector: 8-pos. VS-08-RJ45-5-Q/IP20 1656725 4-pos. VS-PN-RJ45-5-Q/IP20 1658435	FL-PP-RJ45-SCC <sup>1</sup> 2901642 FL-PP-RJ45-SC <sup>1</sup> 2901643 FL-PP-RJ45-LSA 2901645 FL-PP-RJ45/RJ45 <sup>1</sup> 2901646 FL-PP-RJ45/RJ45-B 2904933  FL CAT5 TERMINAL BOX 2744610  PP-RJ-RJ 2703015 PP-RJ-SC 2703016 PP-RJ-SCC 2703018 PP-RJ-RJ-F 2703020 PP-RJ-SC-F 2703021 PP-RJ-SCC-F 2703022	FL RED 2003E PRP 2701863 FL RED 2001E PRP 2LC 2701864
		 Web code: #1579	 #1788, #1799	 Web code: #1579
Approvals		ATEX	G3 <sup>1</sup> ATEX, G3	ATEX

Detailed information and additional approvals can be found at: [phoenixcontact.com/products](http://phoenixcontact.com/products)

# Power supplies for superior system availability

Use high-performance power supplies and compatible device circuit breakers and surge protection to ensure maximum availability of your system.

The QUINT power supply family has peak functionality that makes it ideally suited for process technology: power supplies, DC/DC converters, redundancy modules and uninterruptible power supplies reliably provide your system with power.

At the same time, strong surge protection and individually adjustable device circuit breakers provide effective protection against overvoltage, overloads, and short circuits.



## Power supplies with SIL

Single- or three-phase, for 12, 24, and 48 V DC with power up to 1000 watts. Devices with SIL approval ensure high operational safety. Dip-coated versions with Ex approval protect against 100% humidity.



## Uninterruptible power supply

An uninterruptible power supply provides power even in the event of a power grid failure. DC and AC solutions in the QUINT family enable a variety of applications with various battery technologies.



## Active redundancy modules

Monitor the output voltage, load current, decoupling section, and wiring right up to the redundancy module for the Ex area. Passive redundancy modules are also available.



## Your advantages

- ✓ QUINT POWER power supplies reliably provide power and selectively switch off faulty current paths
- ✓ Use the intelligent QUINT DC UPS to supply the energy storage with uninterruptible power as well as to monitor and optimize it
- ✓ Active QUINT ORING redundancy module for double the service life and for reliably monitoring the load current of redundant power supplies
- ✓ SIL 3 is fulfilled by the new QUINT4 20A power supply and the compatible QUINT S-ORING Plus module.



### Surge protection

High system availability and safety require protection against all types of coupling. Surge protection protects your power supply.



### Device circuit breakers

Reliably protect your system against overloads and short-circuit currents. The circuit breakers ensure high system availability by selectively switching off the faulty circuit.



### Potential distributors

Whether they are used to distribute the operating voltage or the control voltage, the potential distributors are suitable for universal use. The screw or spring-cage connection technology can be selected as required for the application in question.

# Components for power supplies

## Solution for increased availability through redundant power supply concepts

The QUINT POWER power supplies guarantee high functionality and quality. Whether in parallel operation or connected to different phases, the load is reliably supplied with power even if problems arise with the input voltage.

For applications with functional safety based IEC 61508, QUINT POWER can be used up to a safety integrity level of SIL 3.

Power supplies with protective coating are available for extreme requirements with respect to ambient conditions. These power supplies prevent failure caused by electrochemical migration or corrosion-related creepage currents.

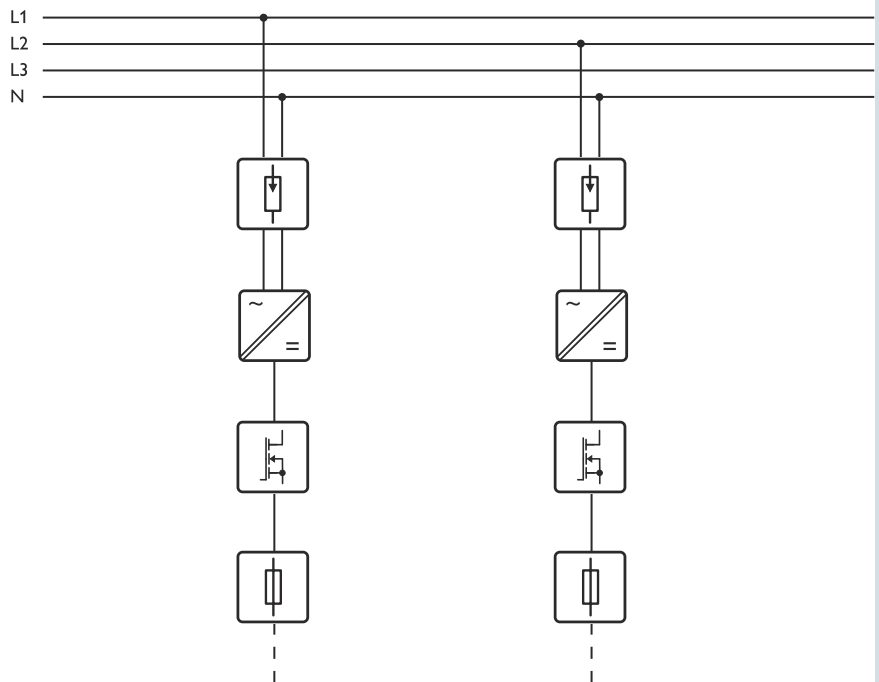

## QUINT POWER for extreme ambient conditions

The protective coating provides optimum protection for all components on the PCB. The QUINT POWER modules with protective coating correspond to EN 60079-15 and EN 60079-0 (ATEX directive) and are permitted for installation in potentially explosive areas with category 3G equipment (II 3 G Ex nA nC IIC T4 Gc). They have been approved in accordance with IECEx (Ex nA nC IIC T4 Gc).



## Functional safety with QUINT

An important aim is to achieve the maximum possible operational safety. The QUINT POWER QUINT4-PS/1AC724DC/20 power supply and the QUINT4-S-ORING/12-24DC/1X40/+ redundancy module can be used in accordance with IEC 61508 as a simple, redundant, and N+1 redundant power supply concept in applications up to SIL 3.



## Power supplies

 Web code: #1513



### Power supplies single-phase

### Power supplies with protective coating

Type	Order No.	QUINT4-PS... ... 1AC/24DC/5 ... 1AC/24DC/10 ... 1AC/24DC/20 <sup>1</sup> ... 1AC/12DC/15 ... 1AC/48DC/5 ... 1AC/48DC/10	2904600 2904601 2904602 2904608 2904610 2904611	QUINT-PS... ... 1AC/24DC/40 ... 1AC/48DC/20	2866789 2866695	QUINT-PS... ... 1AC/24DC/5/CO ... 1AC/24DC/10/CO ... 1AC/24DC/20/CO	2320908 2320911 2320898
Approvals		G3, GL, UL <sup>1</sup> G3, GL, SIL, UL		G3, GL, UL		ATEX, IECEx, G3, GL, UL	
Nominal input voltage		85 V AC ... 264 V AC / 90 V DC ... 350 V DC		85 V AC ... 264 V AC / 90 V DC ... 350 V DC		85 V AC ... 264 V AC / 90 V DC ... 350 V DC	
Nominal output voltage		12 V DC / 24 V DC / 48 V DC		24 V DC / 48 V DC		24 V DC	
Output current		5 A / 10 A / 15 A / 20 A		20 A / 40 A		5 A / 10 A / 20 A	



## Device circuit breakers and surge protection



### Device circuit breakers multi-channel

### Device circuit breakers modular

### Surge protection, device protection

Type	Order No.	CBM E4 24DC/0.5-10A NO-R 2905743 CBM E8 24DC/0.5-10A NO-R 2905744 CBMC E4 24DC/1-4A NO 2906031 CBMC E4 24DC/1-10A NO 2906032	2800859 2800861 2800863 2800837 2800839 2800841 2800929	PLT-SEC-T3-24-FM-UT 2907916 PLT-SEC-T3-60-FM-UT 2907917 PLT-SEC-T3-120-FM-UT 2907918 PLT-SEC-T3-230-FM-UT 2907919 PLT-SEC-T3-24-FM-PT 2907925 PLT-SEC-T3-60-FM-PT 2907926 PLT-SEC-T3-120-FM-PT 2907927 PLT-SEC-T3-230-FM-PT 2907928
		 Web code: #1646	 Web code: #1653	 Web code: #1777
Approvals		UL	UL	GL, UL
Channels		4, 8	1	–
Nominal current		0.5 A ... 16 A	0.5 A ... 16 A	–
One-piece/multipiece		One-piece	Multipiece/pluggable	Multipiece/pluggable
Nominal voltage range		Up to 50 V DC	Up to 50 V DC	230 V AC
Arrester type		–	–	Type 3 arrester (device protection)

Detailed information and additional approvals can be found at [phoenixcontact.com/products](http://phoenixcontact.com/products).

# Components for power supplies

## Solution for increased availability, thanks to two separate networks

QUINT DC/DC converters are used to create a separate power supply with external energy storage devices.

If the power grid fails, the DC/DC converter supplies the load from the battery.

Redundancy modules decouple power supplies operating in parallel. If the wiring is also duplicated, a completely redundant solution can be implemented right up to the consumer. QUINT DIODE modules decouple, while QUINT ORING modules also monitor and control the power supply.

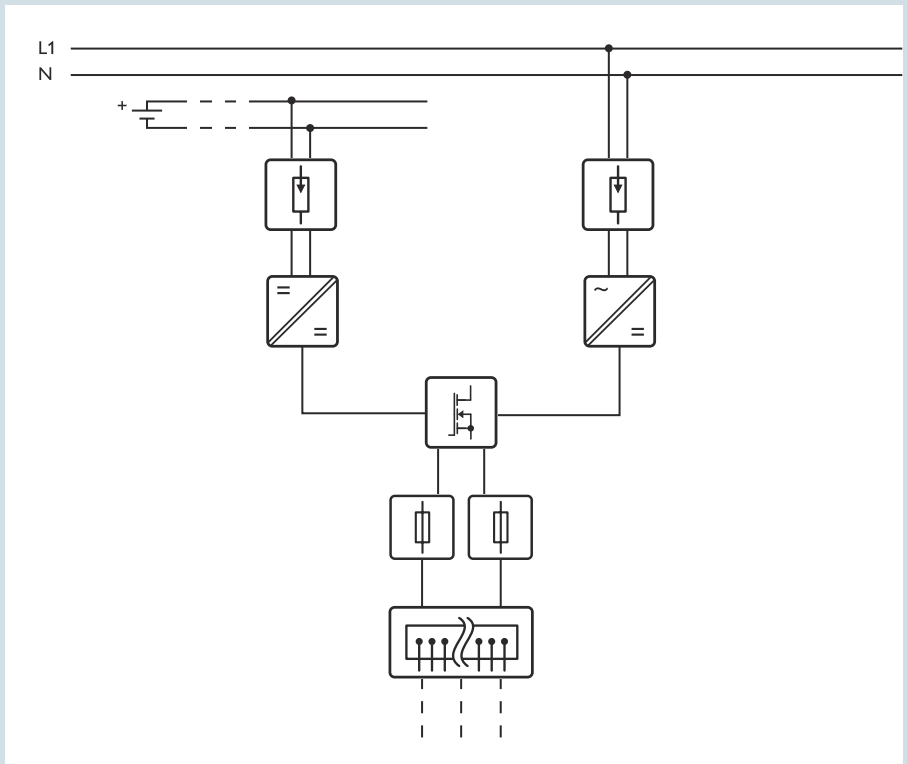

## Solutions for surge protection in a process system

The system to be protected is divided into lightning protection zones (LPZs).









The appropriate lightning and surge protective devices must be installed at the boundaries between zones.

This applies to lines in the areas of power supply, measurement and control technology, data processing, and telecommunications as well as to transmitter and receiver devices.









More surge protection products for your process system are described on page 64 ff.

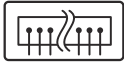

## DC/DC converters and redundancy modules

		 	 	 
		DC/DC converters		Redundancy modules
Type	Order No.	QUINT-PS... ... 24DC/24DC/5 <a href="#">2320034</a> ... 24DC/24DC/10 <a href="#">2320092</a> ... 24DC/24DC/20 <a href="#">2320102</a> ... 24DC/12DC/8 <a href="#">2320115</a> ... 24DC/48DC/5 <a href="#">2320128</a> ... 12DC/12DC/8 <a href="#">2905007</a> ... 48DC/48DC/5 <a href="#">2905008</a>	QUINT-PS... .../24DC/24DC/5/CO <a href="#">2320542</a> .../24DC/24DC/10/CO <a href="#">2320555</a> .../24DC/24DC/20/CO <a href="#">2320568</a>	QUINT-ORING... ... 24DC/2x10/1x20 <sup>1</sup> <a href="#">2320173</a> ... 24DC/2x20/1x40 <sup>1</sup> <a href="#">2320186</a> ... 24DC/2x40/1x80 <a href="#">2902879</a> QUINT4-DIODE... ... 12-24DC/2x20/1x40 <sup>1</sup> <a href="#">2907719</a> ... 48DC/2x20/1x40 <sup>1</sup> <a href="#">2907720</a> QUINT S-ORING... ... 12-24DC/1x40 <a href="#">2907752</a> ... 12-24DC/1x40/+ <sup>1</sup> <a href="#">2907753</a>
		 Web code: <a href="#">#0152</a>	 Web code: <a href="#">#0152</a>	 Web code: <a href="#">#0153</a>
Approvals	G3, GL, UL		ATEX, IECEx, G3, GL, UL	G3, GL, UL <sup>1</sup> ATEX, IECEx, G3, GL, UL
Input voltage range	9 V DC ... 56 V DC		18 V DC ... 30 V DC	8 V DC ... 56 V DC
Nominal output voltage	12 V DC / 24 V DC / 48 V DC		24 V DC	12 V DC / 24 V DC / 48 V DC
Output current	5 A / 8 A / 10 A / 20 A		5 A / 10 A / 20 A	1 x 20 A / 1 x 40 A / 1 x 80 A

## Potential distributors, fuse terminal blocks, and electronic circuit breakers

		 	 	 
		Potential distributors	Fuse terminal blocks	Electronic circuit breakers
Type	Order No.	VIP-2/SC/PDM-2/16 <a href="#">2315256</a> VIP-2/SC/PDM-2/24 <a href="#">2315269</a> VIP-2/SC/PDM-2/32 <a href="#">2315272</a> VIP-3/PT/PDM-2/16 <a href="#">2903797</a> VIP-3/PT/PDM-2/24 <a href="#">2903798</a> VIP-3/PT/PDM-2/32 <a href="#">2903799</a> VIP-3/PT/PDM-2/48 <a href="#">2903800</a> VIP-2/PT/PDM-2/16/FU6.3A <a href="#">2903603</a>	UT 4-HESI (5X20) <a href="#">3046032</a> UT 4-HESILED 24 (5X20) <a href="#">3046090</a> UT 4-HESILED 60 (5X20) <a href="#">3046126</a> PT 4-HESI (5X20) <a href="#">3211861</a> PT 4-HESILED 24 (5X20) <a href="#">3211903</a> PT 4-HESILED 60 (5X20) <a href="#">3207908</a>	PTCB E1 24DC/1-3A NO <a href="#">2909909</a> PTCB E1 24DC/1-4A NO <a href="#">2908261</a> PTCB E1 24DC/1-8A NO <a href="#">2908262</a> PTCB E1 24DC/2A NO <a href="#">2909903</a> PTCB E1 24DC/3A NO <a href="#">2909904</a> PTCB E1 24DC/4A NO <a href="#">2909906</a> PTCB E1 24DC/6A NO <a href="#">2909908</a>
		 Web code: <a href="#">#0489</a>	 Web code: <a href="#">#0075, #1393</a>	 Web code: <a href="#">#1645</a>
Approvals	UL		GL	UL
Number of positions	8 ... 24		–	–
Connection technologies	Screw or spring-cage connection		Push-in or screw connection	Screw connection
Nominal voltage $U_N$	250 V AC/DC		24 V ... 630 V	24 V DC (18 V DC ... 27.5 V DC)
Total current per potential	Max. $\geq 30$ A		–	–
Potential connections (per potential)	2 power terminals up to 24 distributor terminal blocks		–	–
Width	50 mm ... 135 mm		–	–

Detailed information and additional approvals can be found at: [phoenixcontact.com/products](http://phoenixcontact.com/products)

# Components for power supplies

## Solution for increased availability, thanks to an uninterruptible power supply

QUINT DC-UPS uninterruptible power supplies bridge network interruptions and mains failures.

IQ Technology detects all relevant energy storage states. IQ Technology ensures the crucial transparency required to guarantee the stability of the supply and optimum use of the energy storage system at all times.

Phoenix Contact offers uninterruptible power supplies for AC applications in addition to DC solutions.

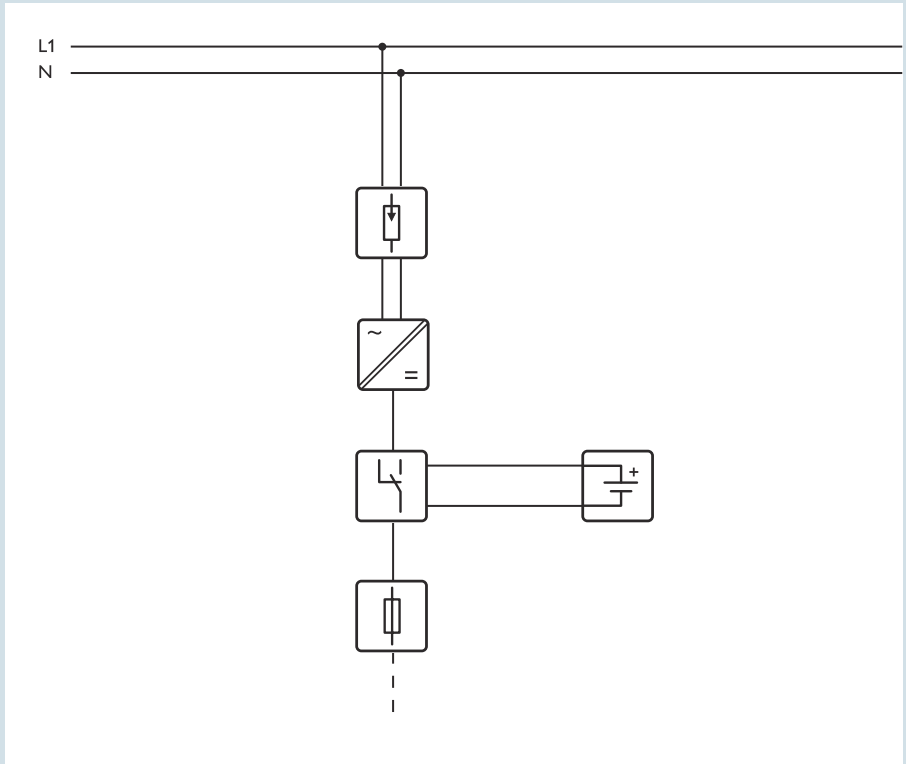

## QUINT DC UPS for Industrial Ethernet

With QUINT DC-UPS, clever IQ Technology monitors and optimizes energy storage, thus ensuring superior system availability. Integrated interfaces let you see the operating state of your system.

Energy monitoring, function monitoring, parameter configuration, and system shut-downs in a safe state are possible at any time, no matter where you are.

Further information about QUINT DC-UPS:

**i** Web code: #1992

### UPS for industrial networks

Integrated interfaces for PROFINET, EtherNet/IP™, EtherCAT® or USB mean that the QUINT DC-UPS can be incorporated easily and flexibly into existing networks.

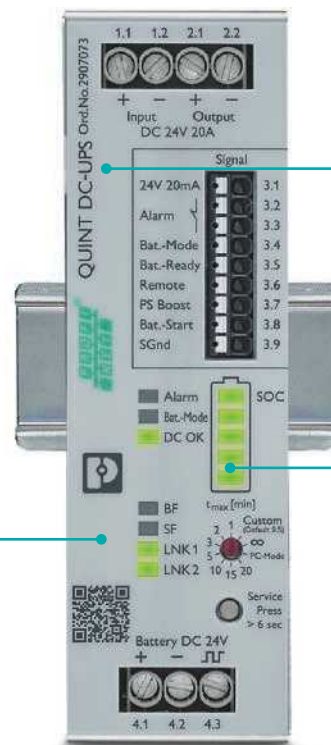

**IQ Technology**  
Designed by PHOENIX CONTACT

### Intelligent battery management

The IQ Technology ensures optimal usage of energy storage.

### Superior system availability

The powerful battery charger with up to 5 A ensures the fastest possible recharging times and enables long buffer times, thanks to large battery capacities.







EtherNet/IP

EtherCAT

USB



## Uninterruptible power supplies and energy storage

 Web code: #0154		 		 	
Technical data		Uninterruptible power supplies		Energy storage systems	
Type	Order No.	<b>PROFINET:</b> QUINT4-UPS/24DC/24DC/.../PN 2906993, 2907068, 2907073, 2907079  <b>EtherCAT®:</b> QUINT4-UPS/24DC/24DC/.../EC 2906994, 2907069, 1907074, 2907080  <b>EtherNet/IP™:</b> QUINT4-UPS/24DC/24DC/.../EIP 2906996, 2907070, 2907076, 2907081	<b>USB:</b> QUINT4-UPS/24DC/24DC/.../USB 2906991, 2907067, 2907072, 2907078  <b>No interface:</b> QUINT4-UPS/24DC/24DC/... 2906990, 2907066, 2907071, 2907077	UPS-BAT/VRLA... .../24DC/1,3AH 2320296 .../24DC/3,4AH 2320306 .../24DC/7,2AH 2320319 .../24DC/12AH 2320322 .../24DC/38AH 2320335 ...-WRT/24DC/13AH 2320416 ...-WRT/24DC/26AH 2320429 UPS-BAT/LI-ION... .../24DC/120 WH 2320351 .../24DC/924WH 2908232	
Approvals		UL	UL	UL	
Nominal voltage		24 V DC	24 V DC	24 V DC	
Input voltage range		18 V DC ... 30 V DC	18 V DC ... 30 V DC	19.2 V DC ... 28 V DC	
Output current		5 A / 10 A / 20 A / 40 A 7.5 A / 15 A / 27 A / 45 A 30 A / 60 A / 120 A / 215 A	5 A / 10 A / 20 A / 40 A 7.5 A / 15 A / 27 A / 45 A 30 A / 60 A / 120 A / 215 A	10 A / 20 A / 40 A	

Detailed information and additional approvals can be found at: [phoenixcontact.com/products](http://phoenixcontact.com/products)

### UPS for AC applications

Protect your system against power failure safely with UPS solutions for AC applications. Our uninterruptible power supplies for AC applications provide a pure sine curve at the output. Select your AC UPS – intelligent with IQ technology or space-saving with integrated energy storage.

Further information about UPS for AC applications:

 Web code: #1986



QUINT4-UPS/1AC/1AC/1KVA, Order No. 2320283

### Properties of the different storage media

Type	Typical buffer time	Temperature	Service life at 20°C	Service life at 50°C	Charging cycles at 20°C	Weight standardized
UPS-CAP...	<5 min.	-40°C ... +60°C	> 20 years	8 years	> 500,000	0.4 kg
UPS-BAT/LI-ION...	>40 min.	-20°C ... +58°C	15 years	2 years	7,000	0.45 kg
UPS-BAT/VRLA-WTR...	>5 h	-25°C ... +60°C	12 years	1.5 years	300	1.3 kg
UPS-BAT/VRLA...	>8 h	0°C ... +40°C	6 years ... 9 years	1 year	250	1 kg

The various storage media feature a wide range of different properties: long service life or very long buffer time, no maintenance or use at extreme temperatures.

# Connection technology and marking

With CLIPLINE complete, the unique terminal block system from Phoenix Contact, you can freely select the connection technology. Whether you opt for Push-in, spring-cage, fast or screw connection technology, all of these connection technologies can be freely combined with each other using the same accessories, thanks to the double bridge shaft. They are all tested in accordance with NE95.

Optimize every process involved in the setup, installation and maintenance of your control cabinets and systems in the field. We offer optimally coordinated products from our marking, tool, and mounting material ranges to help you achieve this.

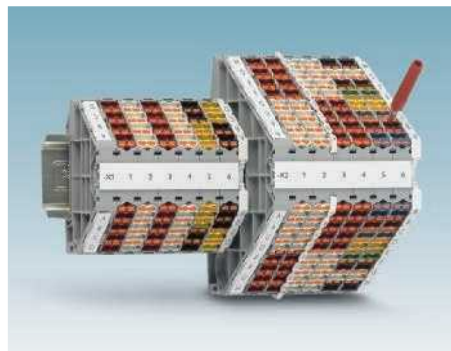
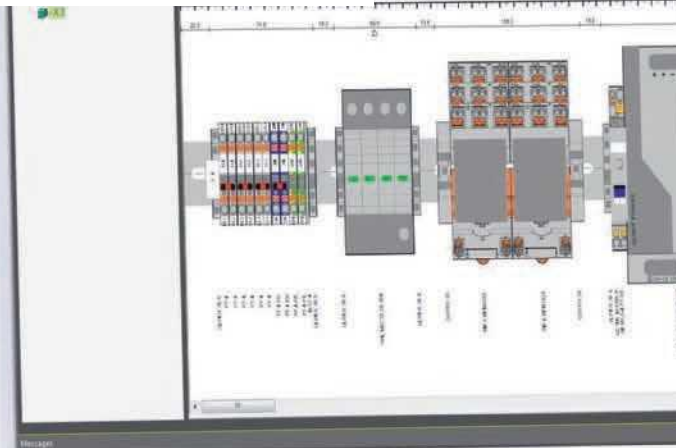

## Connection technology for marshaling

Depending on the application – feed-through or knife disconnection – you can choose between, and combine, single- and multi-level terminal blocks.



## Connection technology for measuring transducer circuits

The test disconnect terminal blocks can be used to set up space-saving individual test strips for all measuring, testing and protection tasks.

## Your advantages

- ✓ Combinable connection technologies
- ✓ Clear labeling options
- ✓ Diverse range of testing and function accessories
- ✓ Simple planning of terminal strips using PROJECT complete software



### Marking systems

Whether you require software, printing systems or marking materials, the MARKING system offers intuitive, user-friendly solutions for all applications, from planning up to the final marking process.



### Tools and mounting material

Control cabinet installation is effortlessly simple with the professional tool and high-quality mounting material from Phoenix Contact.

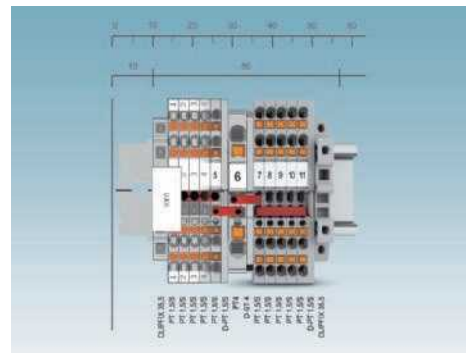

### Planning and marking software

Easily plan your terminal strips using the PROJECT complete software and create the corresponding markings in a single work step.

# Components for connection technology

## PTRV marshaling panel

Marshal sensors and actuators easily and clearly with a compact solution. The configurable color coding ensures quick orientation and secure wiring. Large individually insertable marker carriers enable matrix identification and provide the best possible overview in the control cabinet. Potential distributors of the same shape and a comprehensive range of accessories complete the product range.

You can find the entire range of marshaling panels for use in process technology and process engineering as well as additional accessories at [phoenixcontact.com/products](http://phoenixcontact.com/products)

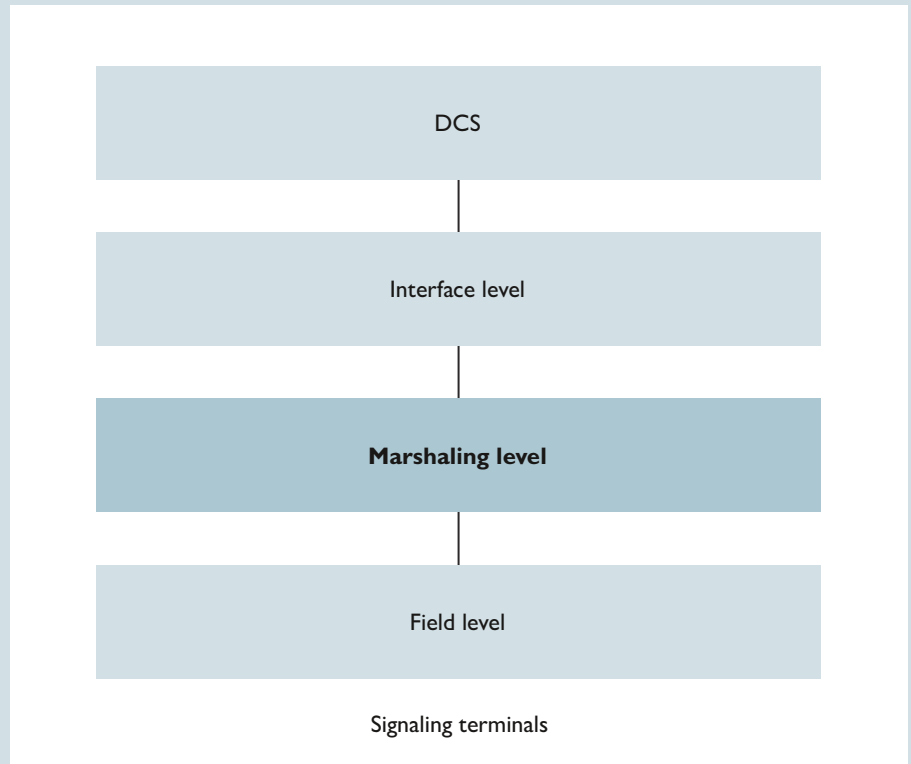

## Color coding for identification of the wiring levels

For a better overview, simple mounting and faster fault analysis, the guide ports of the PTRV can be color-coded. This saves time and increases safety by reducing the risk of incorrect wiring.

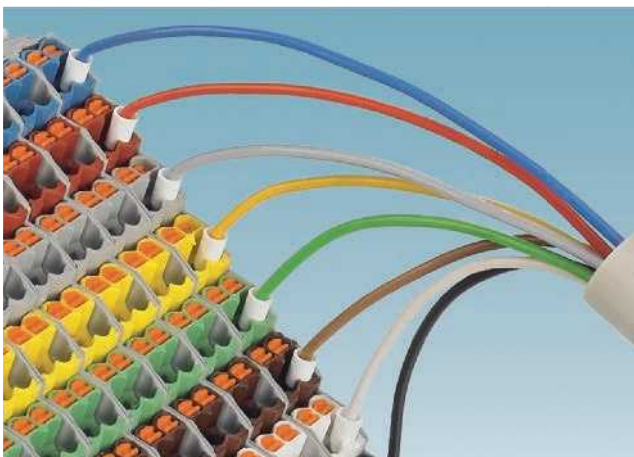

## Many signals in the tightest space

The compact design delivers maximum signal density. The small dimensions result in space savings of up to 20%. Alternating color coding provides an improved overview. A labeling matrix can be set up easily with marking material and pre-marked covers.

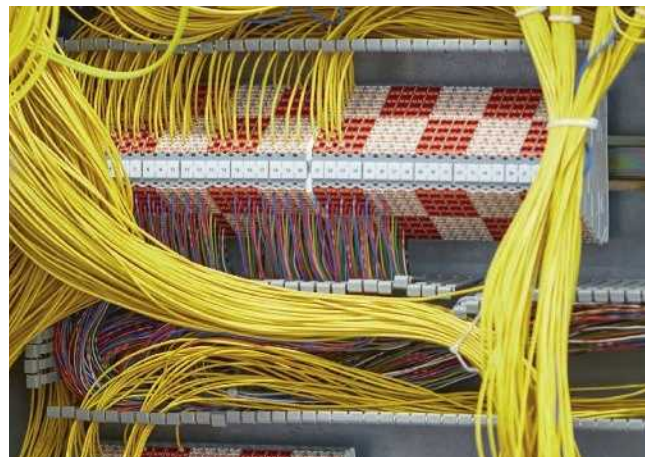

## Marshaling panel

**i** Web code: #0160



		Marshaling panel 4-pos.		Color versions 4-pos.		Marshaling panel 8-pos.		Color versions 8-pos.	
Type	Order No.	PTRV 4 /WH PTRV 4 /RD PTRV 4 BU/WH PTRV 4 BU/RD	3270115 3270121 3270119 3270120	PTRV 4 /GY PTRV 4 /GN PTRV 4 /YE	3270117 3270122 3270123	PTRV 8 /WHRD PTRV 8 /RDWH PTRV 8 BU/WHRD PTRV 8 BU/RDWH	3270133 3270137 3270134 3270135	PTRV 8 /VDE 0815 PTRV 8 /BU PTRV 8 /GY PTRV 8 /RD	3270230 3270233 3270140 3270231
Approvals		GL		GL		GL		GL	
Width x Length x Height [mm]		8.3 x 64 x 55.5		8.3 x 64 x 55.5		8.3 x 100 x 87.5		8.3 x 100 x 87.5	
Rated voltage		250 V		250 V		250 V		250 V	
Nominal current/cross section		10 A / 1.5 mm <sup>2</sup>		10 A / 1.5 mm <sup>2</sup>		8 A / 1.5 mm <sup>2</sup>		8 A / 1.5 mm <sup>2</sup>	
Cross section range [AWG]		26 ... 12		26 ... 12		26 ... 12		26 ... 12	

## Potential distributors

**i** Web code: #0160



		Potential distributors				Potential distributor with 6 mm <sup>2</sup> connection, can be bridged			
Type	Order No.	PTRV 4-PV /BK PTRV 4-PV BU/BK PTRV 4-PV /RD PTRV 4-PV /BU	3270125 3270126 3270246 3270247	PTRV 8-PV /BK PTRV 8-PV BU/BK PTRV 8-PV /RD PTRV 8-PV /BU	3270142 3270145 3270248 3270249	PTRVB 4-FI /RD PTRVB 4-FI /BU PTRVB 4-PV /RD PTRVB 4-PV /BU	3270220 3270221 3270222 3270223	PTRVB 8-FI /RD PTRVB 8-FI /BU PTRVB 8-PV /RD PTRVB 8-PV /BU	3270224 3270225 3270226 3270227
Approvals		GL		GL		GL		GL	
Width x Length x Height [mm]		8.3 x 64 x 55.5		8.3 x 64 x 55.5		8.3 x 100 x 87.5		8.3 x 100 x 87.5	
Rated voltage		250 V		250 V		250 V		250 V	
Rated cross section		17.5 A / 1.5 mm <sup>2</sup>		17.5 A / 1.5 mm <sup>2</sup>		17.5 A / 1.5 mm <sup>2</sup> 32 A / 6 mm <sup>2</sup>		17.5 A / 1.5 mm <sup>2</sup> 32 A / 6 mm <sup>2</sup>	
Cross section range [AWG]		26 ... 12		26 ... 12		26 ... 12		26 ... 12	

Detailed information and additional approvals can be found at: [phoenixcontact.com/products](http://phoenixcontact.com/products)

# Connection technology

## Marshaling patchboards PTMC

Marshal sensors and actuators easily and clearly with a compact solution. The configurable color coding ensures quick orientation and secure wiring. Large individually insertable marker carriers enable matrix identification and provide the best possible overview in the control cabinet.

You can find the entire range of marshaling patchboards for use in process technology and process engineering as well as additional accessories at [phoenixcontact.com/products](http://phoenixcontact.com/products)

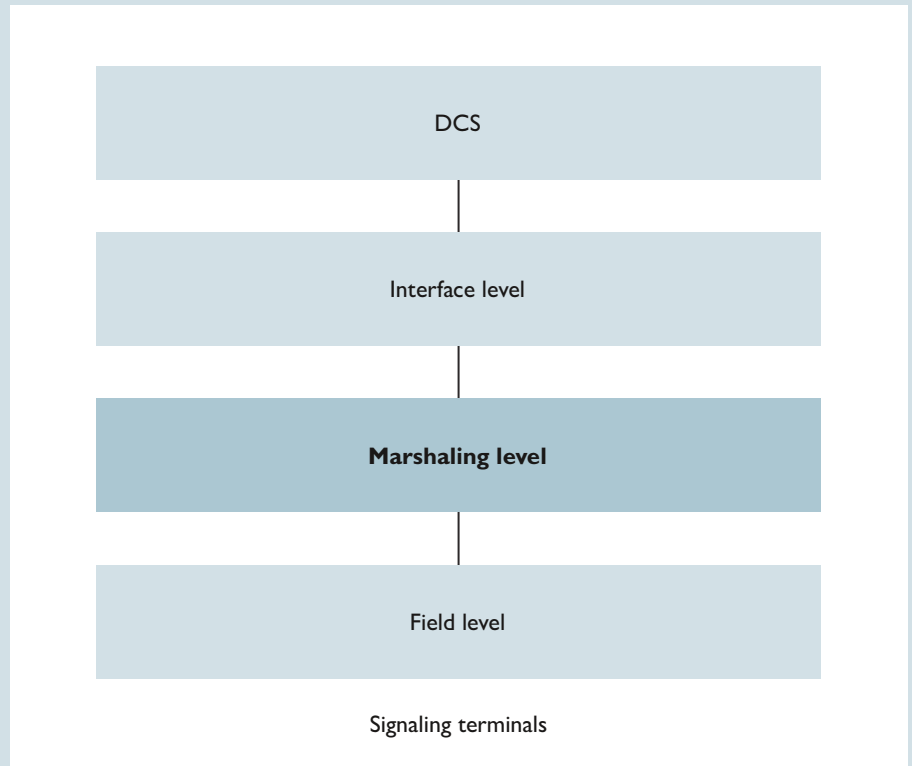

## 19" versions

Marshaling patchboards that fit the 19" housing in accordance with the DIN EN 60297-3-101 standard save time during mounting in a 19" rack.

Thanks to the narrow 34.4 mm design, 448 connector panels can be installed in a rack with three rack units. Every panel here has four connections and an additional test point.



## Marshaling patchboards with color code

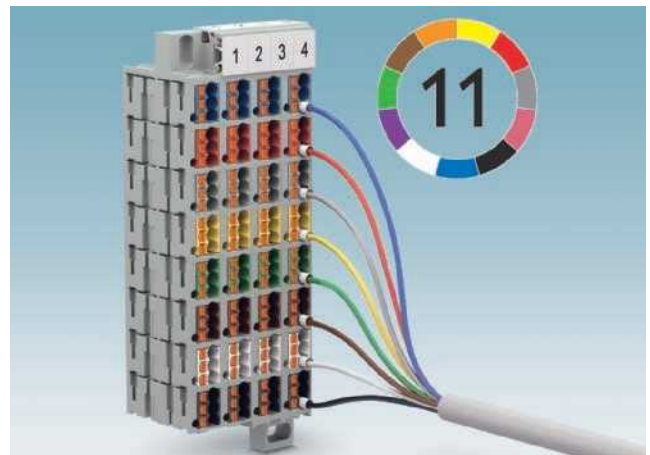

Standardized or customized color-coded marshaling patchboards simplify mounting and fault analysis. A choice of eleven different colors provides an ideal overview with high signal density.



## Marshaling patchboards

 Web code: #0161				
		<b>19" versions 32-pos.</b>	<b>19" versions 48-pos.</b>	<b>19" versions 80-pos.</b>
Type	Order No.	Gray/white Blue VDE 0815 <a href="#">3270311</a> <a href="#">3270313</a> <a href="#">3270394</a>	Gray/white Blue <a href="#">3270319</a> <a href="#">3270321</a>	Gray/white Blue <a href="#">3270325</a> <a href="#">3270327</a>
Approvals		UL	UL	UL
Width x Length x Height [mm]		44 x 111 x 30	66 x 111 x 30	110 x 111 x 30
Rated voltage		500 V	500 V	500 V
Nominal current/cross section		17.5 A / 1.5 mm <sup>2</sup>	17.5 A / 1.5 mm <sup>2</sup>	17.5 A / 1.5 mm <sup>2</sup>
Cross section range [AWG]		26 ... 12	26 ... 12	26 ... 12

## Marshaling patchboards with narrow design

 Web code: #0161				
		<b>19" versions extra narrow</b>		
Type	Order No.	Gray/white Blue (Ex i) VDE 0815 <a href="#">3270316</a> <a href="#">3270317</a> <a href="#">3270395</a>		
Approvals		UL		
Width x Length x Height [mm]		34.4 x 111 x 30		
Rated voltage		500 V		
Nominal current/cross section		17.5 A / 1.5 mm <sup>2</sup>		
Cross section range [AWG]		26 ... 12		

Detailed information and additional approvals can be found at: [phoenixcontact.com/products](http://phoenixcontact.com/products)

# Connection technology

## Feed-through terminal blocks and ground terminals for marshaling and field distribution

Terminal blocks from Phoenix Contact satisfy all requirements. The compact terminal blocks, with an overall width starting at just 3.5 mm, fit in any control cabinet. Single terminal blocks and double-level terminal blocks in many different colors and sizes support a wide range of possible applications in the field of marshaling. Designed in accordance with Ex i (EN 60079-11) or approved in accordance with Ex e (EN 60079-07), all terminal blocks fulfill the requirements of process technology. The range of terminal blocks is rounded off by comprehensive documentation of approvals and installation notes. In addition to marshaling process signals, grounding is also necessary to ensure the signal quality and therefore error-free operation of the system. Phoenix Contact offers a comprehensive range of ground terminals with snap-on PE foot for the various connection technologies.

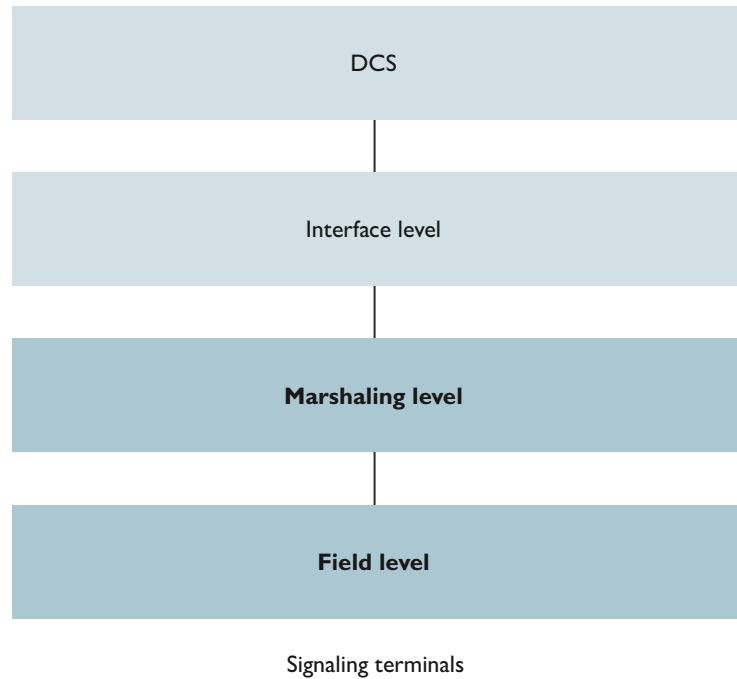

## Terminal boxes with explosion protection

The CLIPSAFE stainless steel enclosures provide comprehensive protection for your applications in industrial environments and in process technology areas. On request, the housing can also be delivered completely equipped with terminal blocks and cable glands. The housings are delivered with corresponding component approval in accordance with ATEX and IECEx.













## Clear signal connection in the field

Terminal blocks from Phoenix Contact offer various options for marking the terminal point. This provides a clear overview and safety during installation, startup and maintenance.









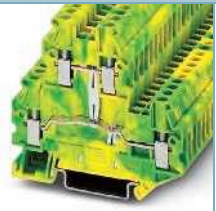

## Feed-through terminal blocks

						
		<b>Feed-through terminal blocks with fast connection</b>	<b>Feed-through terminal blocks with screw connection</b>	<b>Feed-through terminal blocks with Push-in connection</b>	<b>Double-level terminal block with screw connection</b>	<b>Double-level terminal block with Push-in connection</b>
Type	Order No.	QTC ... ...1,5 3205019 ...1,5 BU 3205022	UT ... ...2,5 3044076 ...2,5 BU 3044089 ...2,5 FE 3245121	PT ... ...1,5/S 3208100 ...1,5/S BU 3208126	UTT ... ...2,5 3044636 ...2,5 BU 3044649 ...2,5-PV 3044652	PTTB ... ...1,5/S 3208511 ...1,5/S BU 3208524 ...1,5/S-PV 3208540
		 Web code: #0053	 Web code: #0056	 Web code: #0068	 Web code: #0056	 Web code: #0068
Approvals		ATEX, IECEx, GL, UL	ATEX, IECEx, GL, UL	ATEX, IECEx, GL	ATEX, IECEx, GL, UL	ATEX, IECEx, GL
Width x Length x Height [mm]		5.2 x 58.8 x 39.3	5.2 x 47.7 x 47.5	3.5 x 45 x 32	5.2 x 69.9 x 65	3.5 x 65.4 x 42.6
Rated voltage		800 V	1000 V	500 V	500 V	500 V
Nominal current/cross section		17.5 A / 1.5 mm <sup>2</sup>	24 A / 2.5 mm	17.5 A / 1.5 mm <sup>2</sup>	24 A / 2.5 mm	16 A / 1.5 mm
Cross section range [AWG]		24 ... 16	26 ... 12	26 ... 14	26 ... 12	26 ... 14

## Ground terminals

						
		<b>Ground terminal with fast connection</b>	<b>Ground terminal with screw connection</b>	<b>Ground terminal with Push-in connection</b>	<b>Double-level ground terminal with screw connection</b>	<b>Double-level ground terminal with Push-in connection</b>
Type	Order No.	QTC 1,5-PE 3205035	UT 2,5-PE 3044092	PT 1,5/S-PE 3208139	UTT 2,5-PE 3044665	PTTB 1,5/S-PE 3208537
		 Web code: #0053	 Web code: #0056	 Web code: #0068	 Web code: #0056	 Web code: #0068
Approvals		ATEX, IECEx, GI, UL	ATEX, IECEx, GL, UL	ATEX, IECEx, GL	ATEX, IECEx, GL, UL	ATEX, IECEx, GL
Width x Length x Height [mm]		5.2 x 58.8 x 39.3	5.2 x 47.7 x 47.5	3.5 x 45 x 32	5.2 x 69.9 x 65	3.5 x 65.4 x 42.6
Rated cross section		1.5 mm	2.5 mm	1.5 mm	2.5 mm	1.5 mm
Cross section range [AWG]		24 ... 16	26 ... 12	26 ... 14	26 ... 12	26 ... 14

Detailed information and additional approvals can be found at: [phoenixcontact.com/products](http://phoenixcontact.com/products)

# Connection technology

## Knife disconnect terminal blocks for marshaling

Single-level or double-level terminal blocks with knife disconnection are used for marshaling and isolating input and output signals. Measurements are taken on the signal path using integrated test sockets.

You can find the entire range of knife disconnect terminal blocks for process technology and process engineering as well as additional accessories (including those relating to testing and measurement) plus additional information and complete technical data at [phoenixcontact.com/products](http://phoenixcontact.com/products)

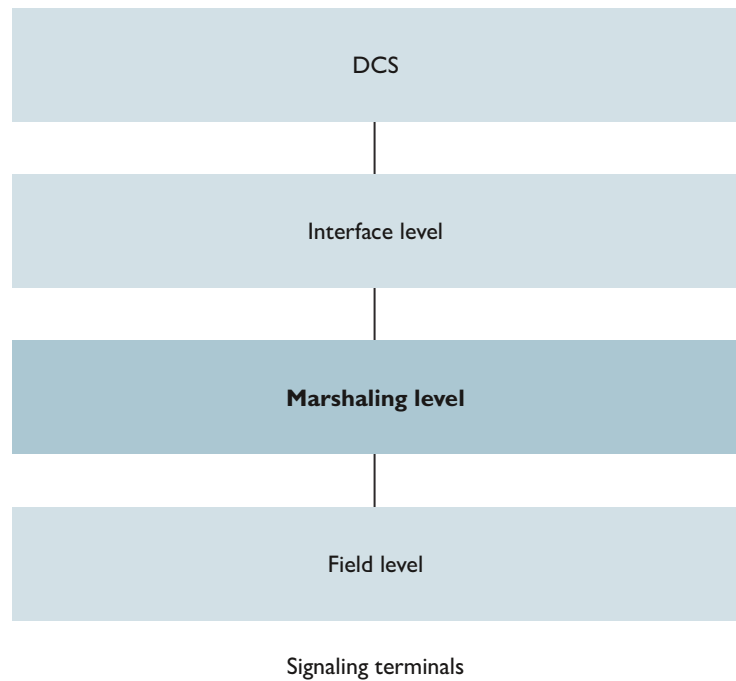

## Space-saving wiring in the signal cabinet

Using space-saving double-level terminal blocks with a pitch width of 3.5 mm, signals up to 1.5 mm<sup>2</sup> are wired in the control cabinet. Consequently, it is possible to incorporate up to 570 signals (+/- connection) in one standardized signal cabinet on a vertically installed terminal strip.







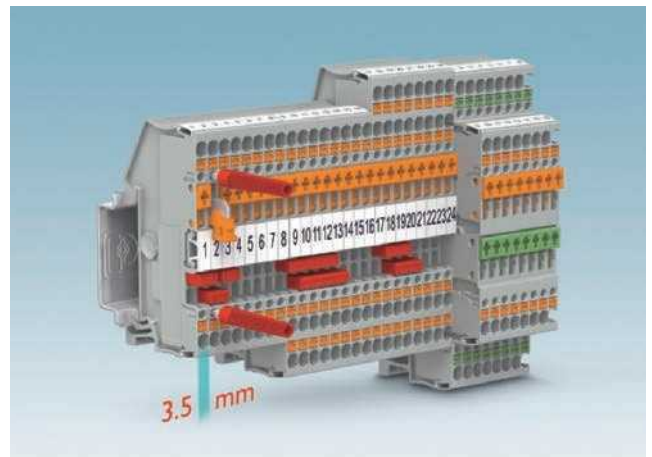





## Simple signal isolation





With knife disconnect terminal blocks, simple isolation is possible using a conventional screwdriver. Furthermore, testing can be performed using the 2.3 mm test opening at any time.



## Knife disconnect terminal block

						
		Knife disconnect terminal block with fast connection	Knife disconnect terminal block with screw connection	Knife disconnect terminal block with screw connection	Knife disconnect terminal block with Push-in connection	Knife disconnect terminal block with Push-in connection
Type	Order No.	QTC 1,5-... ...MT 3205103 ...MT BU 3205213	UT 2,5-... ...MT 3046362 ...MT BU 3046553	UT 4-MT-... ...EX <sup>1</sup> 3046141 ...P/P-EX 3046173	PT 1,5/S-... ...MT 3210301 ...MT BU 3210302	PTTB 4-... ...MT 3211913 ...MT BU 3211915
		 Web code: #0054	 Web code: #0070	 Web code: #0070	 Web code: #0070	 Web code: #0070
Approvals		GL	–	ATEX, IECEx <sup>1</sup> ATEX, IECEx, UL	GL	–
Width x Length x Height [mm]		5.2 x 76.4 x 39.3	5.2 x 57.8 x 49.1	6.2 x 57.8 x 49.1	3.5 x 58.9 x 32	6.2 x 102.9 x 56.5
Rated voltage		400 V	400 V	500 V	400 V	500 V
Nominal current/cross section		17.5 A / 1.5 mm <sup>2</sup>	20 A / 2.5 mm <sup>2</sup>	20 A / 4 mm <sup>2</sup>	10 A / 1.5 mm <sup>2</sup>	28 A / 6 mm <sup>2</sup>
Cross section range [AWG]		24 ... 16	26 ... 12	26 ... 10	26 ... 14	24 ... 10

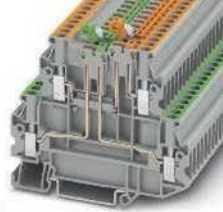
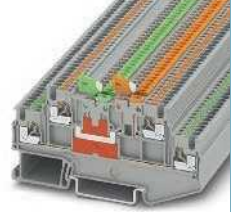
## Double-level knife disconnect terminal block

 Web code: #0070					
		Double-level knife disconnect terminal block with screw connection	Double-level knife disconnect terminal block with screw connection	Double level knife disconnect terminal block with Push-in connection	Double level knife disconnect terminal block with Push-in connection
Type	Order No.	UTT 2,5-MT-P/P 3044640 UTT 2,5-MT-P/P BU 3044641	UTT 2,5-2MT-P/P <sup>1</sup> 3044670 UDMTK 5-P/P BU 3101113 UDMTKB 5-P/P 3024478 UTT 2,5-2MT-P/P BU <sup>1</sup> 3044671	PTT 1,5/S-2MT 3210351 PTT 2,5-2MT BU <sup>1</sup> 3210265	PTTB 2,5-2MTB 3210400 PTTB 2,5-2MTB BU 3210401
Approvals		–	IECEX <sup>1</sup> No specific approvals	GL <sup>1</sup> No specific approvals	GL
Width x Length x Height [mm]		5.2 x 69.9 x 65	5.2 x 80.1 x 65	3.5 x 86 x 42.6	5.2 x 127.5 x 64.3
Rated voltage		400 V	400 V	400 V	400 A
Nominal current/cross section		22 A / 2.5 mm <sup>2</sup>	16 A / 2.5 mm <sup>2</sup>	9 A / 1.5 mm <sup>2</sup>	16 A / 2.5 mm <sup>2</sup>
Cross section range [AWG]		26 ... 12	26 ... 12	26 ... 14	26 ... 12

Detailed information and additional approvals can be found at: [phoenixcontact.com/products](http://phoenixcontact.com/products)

# Connection technology

## Fuse and function terminal blocks

Single and multi-level fuse and function terminal blocks are suitable for use in applications that require Ex approval. They offer a single-sided PE connection, a feed-through level, plus a level with fuse lever. Furthermore, there are terminal versions with a disconnect knife or standard disconnect zone.

The entire terminal block range for process technology and process engineering as well as additional accessories for testing and measuring can be found at: [phoenixcontact.com/products](http://phoenixcontact.com/products)

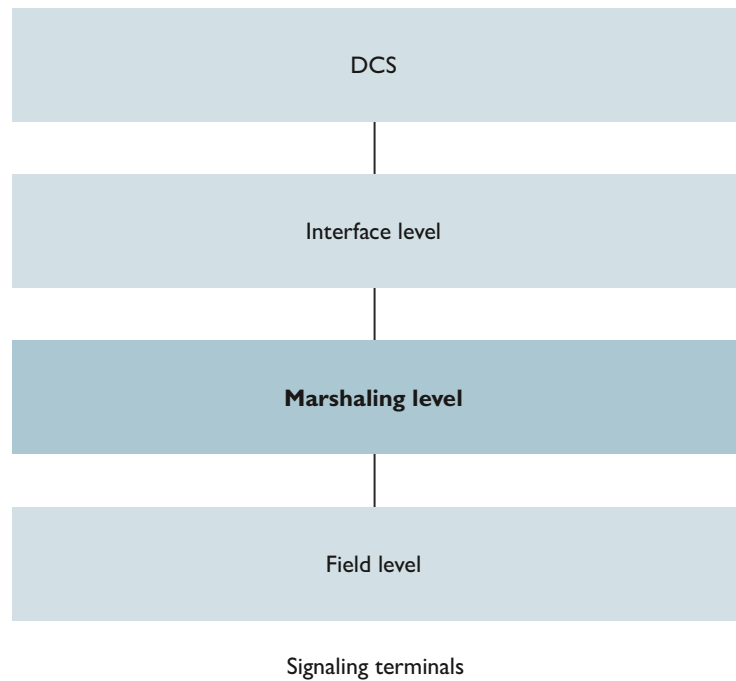

## Signal fuse

Fuse terminal blocks for accommodating 5 x 20 mm cartridge fuses with and without PE connection for convenient protection of the signal path. Can be used with a universal screw terminal block or time-saving Push-in connection. Simple indication of fuse tripping possible with red LED at 24 V/60 V/250 V.

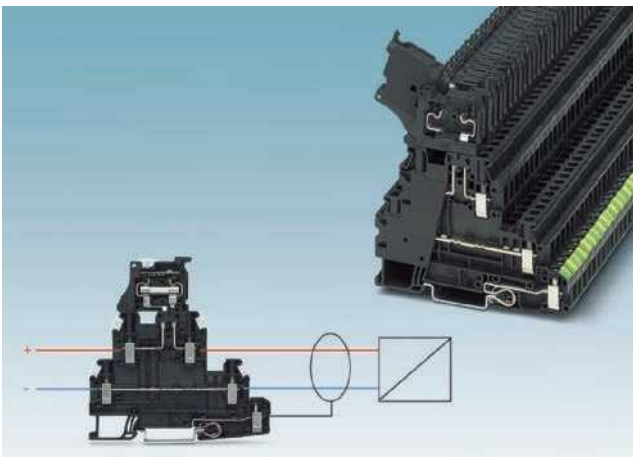

## Added value through a function



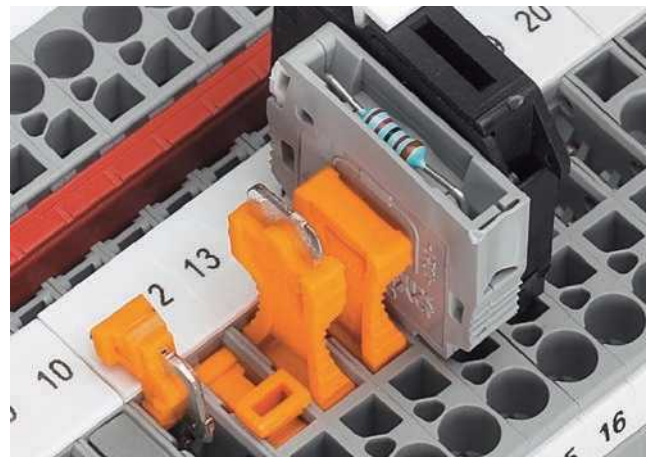





Function terminals with a standardized disconnect zone offer a convenient option for isolating, protecting and testing signals and for connecting modules. This is possible, thanks to an extensive accessory range.



## Lever-type fuse terminal block

						
		Lever-type fuse terminal block with fast connection	Lever-type fuse terminal block with screw connection	Lever-type fuse terminal block with Push-in connection	Fuse terminal block with PE foot	Double-level fuse terminal block with Push-in connection
Type	Order No.	QTC 2,5-HESI (5X20) 3050293 QTC 2,5-HESI LED 24 (5X20) 3050374 QTC 2,5-HESI LED 60 (5X20) 3050390 QTC 2,5-HESILA 250 (5X20) 3050387	UT 4-HESI (5X20) 3046032 UT 4-HESI LED 24 (5X20) 3046090 UT 4-HESI LED 60 (5X20) 3046126 UT 4-HESILA 250 (5X20) 3046100 UT 4-HESI LED 24 (5X20) 820KOHM 3036826	PT 4-HESI (5X20) 3211861 PT 4-HESI LED 24 (5X20) 3211903 PT 4-HESI LED 60 (5X20) 3207908 PT 4-HESILA 250 (5X20) 3211907	PT 4-PE/L/HESI (5X20) 3002602 PT 4-PE/L/HESI LED 24 (5X20) 3002603 PT 4-PE/L/HESI LED 60 (5X20) 3002604 PT 4-PE/L/HESI LED 250 (5X20) 3002605	PTTB 4-HESI-EX (5X20) 3211895 PTTB 4-HESI LED 24-EX (5X20) 3211897 PTTB 4-HESI LED 60-EX (5X20) 3211899 PTTB 4-HESI LED 250-EX (5X20) 3211901
		 Web code: #0162	 Web code: #0075	 Web code: #1393	 Web code: #1393	 Web code: #1393
Approvals		GL, UL	GL	GL	–	–
Width x Length x Height [mm]		6.2 x 82.5 x 64.9	6.2 x 57.8 x 73	6.2 x 56 x 62.5	6.2 x 83.9 x 118.5	6.2 x 75.5 x 102.9
Rated voltage		24 V ... 500 V	24 V ... 500 V	24 V ... 500 V	500 V	500 V
Nominal current/cross section		6.3 A / 2.5 mm <sup>2</sup>	6.3 A / 4 mm <sup>2</sup>	6.3 A / 4 mm <sup>2</sup>	6.3 / 4 mm <sup>2</sup>	6.3 A / 4 mm <sup>2</sup>
Cross section range [AWG]		20 ... 14	26 ... 10	24 ... 10	–	–

## Fuse / function terminal blocks

					
		Fuse terminal block with PE foot	Fuse terminal block with PE foot	Basic terminal block for fuse plugs	Double-level terminal block with disconnect zone
Type	Order No.	UT 4-PE/HESI (5X20) 3073995 UT 4-PE/HESI LED 24 (5X20) 3070053 UT 4-PE/HESI LED 60 (5X20) 3070066 UT 4-PE/HESILA 250 (5X20) 3070079	UT 4-PE/L/HESI (5X20) 3214320 UT 4-PE/L/HESI LED 24 (5X20) 3214321	UT 4-TG-EX 3046143 UT 4-TG-P/P-EX 3046169	PTTB 4-TG 3211909 PTTB 4-TG BU 3211911
		 Web code: #0075	 Web code: #0075	 Web code: #0075	 Web code: #0070
Approvals		ATEX, IECEx, UL	ATEX, IECEx, UL	ATEX, IECEx, UL	–
Width x Length x Height [mm]		6.2 x 92.7 x 88.9	6.2 x 92.7 x 88.9	6.2 x 57.8 x 47.5	6.2 x 102.9 x 54.9
Rated voltage		24 V ... 500 V	24 V ... 500 V	500 V	500 V
Nominal current/cross section		6.3 A / 4 mm <sup>2</sup>	6.3 A / 4 mm <sup>2</sup>	20 A / 4 mm <sup>2</sup>	28 A / 6 mm <sup>2</sup>
Cross section range [AWG]		26 ... 10	26 ... 10	26 ... 10	24 ... 10

Detailed information and additional approvals can be found at: [phoenixcontact.com/products](http://phoenixcontact.com/products)

# Connection technology

## Test disconnect terminal blocks for power distribution

The ME series test disconnect terminal blocks enable simple and individualized setup of measuring transducer terminal strips. The plug-in accessories for testing and short circuiting current transformers as well as the potential distribution are placed inside the terminal strip, depending on the application. All switching statuses inside the terminal strip are clearly recognizable.

Feed-through and ground terminals with the same shape as well as up to six function shafts in the series offer ideal application options in measurement and control engineering, from the counter right up to the secondary technology of switching devices and power stations. The test disconnect terminal blocks are available with in screw connection and Push-in connection technology versions.

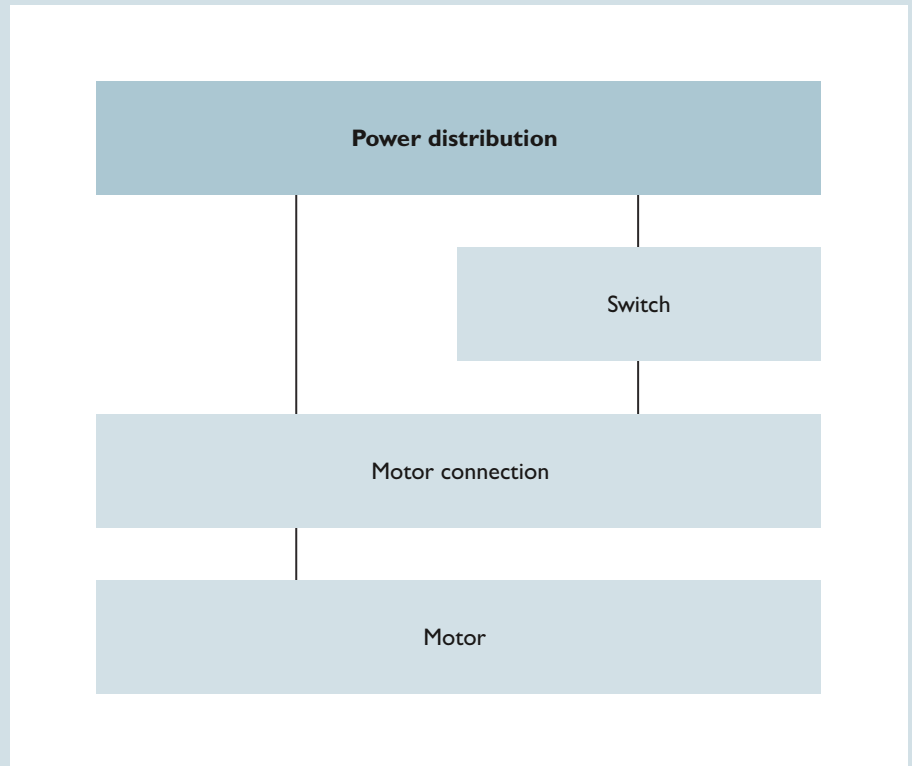









## Application-based test terminal strips

Easy, individualized setup of test terminal strips is possible with pluggable accessories such as current transformer short-circuit jumpers, test sockets and plug-in bridges. Covers with sealing options are also installed.



## Test disconnect terminal block

					
		Test disconnect terminal block, 4 mm <sup>2</sup> , with screw connection	Test disconnect terminal block, 4 mm <sup>2</sup> , with Push-in connection	Test disconnect terminal block, 6 mm <sup>2</sup> , with screw connection	Test disconnect terminal block, 6 mm <sup>2</sup> , with Push-in connection
Type	Order No.	UTME 4 UTMED 4 UTMED 4-PE	PTME 4 PTMED 4 PTMED 4-PE	UTME 6 UTMED 6 UTMED 6-PE	PTME 6 PTMED 6 PTMED 6-PE
		3047452 3047465 3047478	3212139 3212141 3212154	3047400 3047413 3047442	3212170 3212183 3212196
		 Web code: #0058	 Web code: #0071	 Web code: #0058	 Web code: #0071
Width x Length x Height [mm]		6.2 x 66 x 47.7	6.2 x 70.5 x 49.5	8.2 x 100.8 x 49.6	8.2 x 100.8 x 49.6
Approvals		–	–	–	–
Rated voltage		500 V	500 V	500 V	500 V
Nominal current/cross section		28 A / 4 mm <sup>2</sup>	24 A / 4 mm <sup>2</sup>	30 A / 6 mm <sup>2</sup>	30 A / 6 mm <sup>2</sup>
Cross section range [AWG]		24 ... 12	24 ... 12	24 ... 10	24 ... 10

Detailed information and additional approvals can be found at: [phoenixcontact.com/products](http://phoenixcontact.com/products)

## Counting, measuring, testing

The flexible combination options of disconnect terminal blocks with feed-through and PE terminal blocks in the same shape enable use in nearly all energy supply measuring and testing structures.



# Marking

## Laser marking system for challenging industrial identification



Robust and clear marking in the field is crucial for system operators in process technology and process engineering. Responses can be quick and accurate during diagnostics, thus minimizing system downtimes.

The TOPMARK NEO laser marking system fulfills these high requirements, marking stainless steel, aluminum, ABS, polyacrylic and polycarbonate directly, permanently and reliably. Print data is entered simply and intuitively using the integrated operating display. The integrated magazine enables an automatic stacking and de-stacking function of UCT sheets for quickly processing large volumes of material. Integration in the PROJECT complete planning and marking software allows for large amounts of print

data to be prepared on the PC and for projects to be transmitted directly for immediate processing on the laser. At up to 250 marking signs per minute, the TOPMARK NEO is this the fastest desktop laser marker in its class.





### Cable markers

 Web code: #1978	
Type Order no.	LS-WMTB-V4A (29X8) 0831516
Material	Stainless steel
Mounting type	Assembly with cable binders
Lettering field	29 mm x 8 mm

### Device marker

 Web code: #1979	
Type Order no.	LS-EMSP-V4A (39X15) 0831653
Material	Stainless steel
Mounting type	Screws/rivets
Lettering field	39 mm x 15 mm
	
Type Order no.	LS-EMLP (11X9) WH 0831678
Material	TRANSPLY-ABS
Mounting type	Adhesive
Lettering field	11 mm x 9 mm







### Terminal markers



 Web code: #1980	
Type Order no.	UCT-TM 5 0828734
Material	PC V0
Mounting type	Snapping on
Lettering field	4.6 x 10.5 mm

Detailed information and additional approvals can be found at: [phoenixcontact.com/products](http://phoenixcontact.com/products)



				
LS-WMTB-AL (29X8) 0831500	LS-WMTB-AL (29X8) BK 0831508	LS-WMTB-V4A (D25) 0831520	LS-WMTB-AL (D25) 0831504	LS-WMTB-AL (D25) BK 0831512
Aluminum	Aluminum	Stainless steel	Aluminum	Aluminum
Assembly with cable binders	Assembly with cable binders	Assembly with cable binders	Assembly with cable binders	Assembly with cable binders
29 mm x 8 mm	29 mm x 8 mm	25 mm	25 mm	25 mm

				
LS-EMSP-AL (39X15) 0831615	LS-EMSP-AL (50X30) RD 0831637	LS-EMLP-AL (27X15) 0831580	LS-EMSP-AL (50X30) HN 0831649	LS-EMP-AL (27X15) 0831661
Aluminum	Aluminum	Aluminum	Aluminum	Aluminum
Screws/rivets	Screws/rivets	Adhesive	Adhesive	Snap-in
39 mm x 15 mm	50 mm x 30 mm	27 mm x 15 mm	60 mm x 30 mm	27 mm x 15 mm
				
LS-EMLP (11X9) YE 0831732	LS-EMLP 24 (30X12) WH 0831700	LS-EMLP 24 (30X12) YE 0831754	LS-EML (180X180) BK-WH 0831784	
TRANSPLY-ABS	TRANSPLY-ABS	TRANSPLY-ABS	Polyacrylate	
Adhesive	Adhesive	Adhesive	Adhesive	
60 mm x 30 mm	30 mm x 12 mm	30 mm x 12 mm	180 mm x 180 mm	

				
UCT-WMCO 2,9 (18X4) 0830783	UCT-WMS 3,2 (12X4) 0828570			
PC V0	PC V0			
Clip on	Slide on			
18 mm x 4 mm	12 mm x 4 mm			



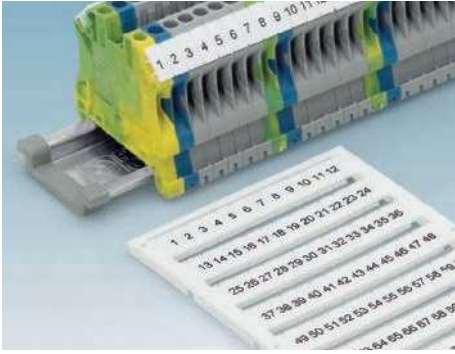

### UC-TM/-TMF UniCard markers

PA markers in tall, flat design for terminal marking.

**i** Web code: #1963

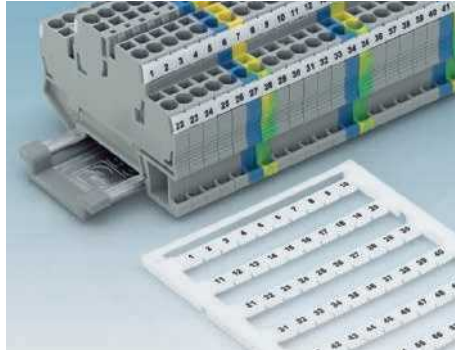

### UCT-TM/-TMF UniCard markers

PC markers in tall, flat design for terminal marking.

**i** Web code: #1982

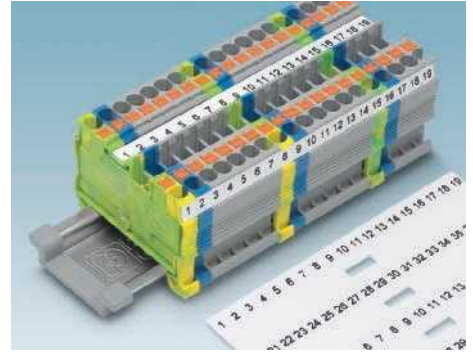

### US-TM UniSheet markers

Pre-stamped marking strips for universal marker grooves.

**i** Web code: #1983



### UC-WMT UniCard markers

PA wire markers for pushing into PATG/PATO sleeves.

**i** Web code: #1965



### UC-WMTBA UniCard markers

PA wire markers for mounting with cable binders.

**i** Web code: #1966



### WMS shrink sleeves

Material off the roll in never-ending format for cable and wire marking.

**i** Web code: #1984



### EML-Ex labels

Self-adhering device markers in roll format for explosion-protected areas.

**i** Web code: #1968



### PML warning labels

PVC labels in roll format for system identification.

**i** Web code: #1970



### P(L)P-RFID and UC-PM(I)P

Marking labels with and without RFID transponders for pipes and systems.

**i** Web code: #2004

# Tools and mounting material

## Solution concepts for the setup, installation and maintenance of your control cabinets and systems

Optimize all of the processes involved in the setup, installation, and maintenance of your control cabinets and switching devices. We can help you achieve this with optimally coordinated products from our tool and mounting material ranges. The TOOL fox portfolio includes high-quality tools for cutting, stripping, crimping, screwing and measuring and offers the right solution for any application. Control cabinets and switching devices can be set up effortlessly, reliably and according to standards with the installation and mounting material of the CABINET

add-on range. Suitable mounting devices and the choice of the right tool save time and space in control cabinet manufacturing. This facilitates successful implementation of projects.



### CUTFOX cutting tools

Optimal cable cutter for any application in high-quality design.

**i** Web code: #1956



### SK shield connection clamps

Screw-on shield clamps for the busbar or direct mounting.

**i** Web code: #1962



### CD, CD-HF cable ducts

Installation channels in various sizes and colors, also halogen-free.

**i** Web code: #1961



Detailed information and additional approvals can be found at: [phoenixcontact.com/products](http://phoenixcontact.com/products)



### WIREFOX stripping tools

Fast, precise and safe removal of insulation from conductors and wires.

**i** Web code: #1957



### CRIMPFOX crimping tools

Reliable processing of ferrules and connectors up to 120 mm<sup>2</sup>.

**i** Web code: #1958



### CRIMPHANDY

Portable stripping and crimping device for processing ferrules.

**i** Web code: #1273

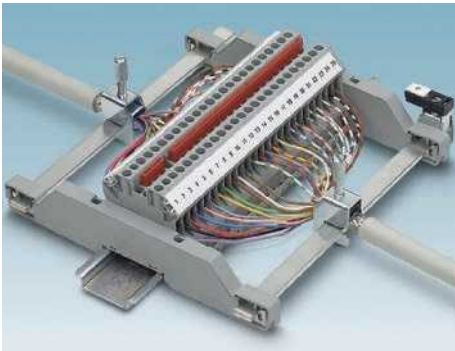

### AB-SK shield support brackets

Convenient shield connection, especially for single- and multi-level terminal blocks.

**i** Web code: #1959



### AGK connection terminal blocks

For connecting N, PE or outer L conductors on central busbars.

**i** Web code: #1971



### NS DIN rails

Metal rails in various materials, sizes, and designs.

**i** Web code: #1960



### WP protective hoses

Designs made of metal and plastic protect against external influences.

**i** Web code: #0572



### WT cable binders

For bundling and fastening cables and conductors, various designs.

**i** Web code: #0573



### KMK cable binders with lettering field

Designs made of metal and plastic protect against external influences.

**i** Web code: #1972

# Planning and marking software

## Process innovations for control cabinet manufacturing

The PROJECT complete software is the most innovative solution to date, letting you plan your terminal strip with ease. The direct data exchange with all current CAE software solutions, as well as the creation of all project documentation, makes this software unique.

The high-performance marking tool optimally supports all output devices and marking materials. Design your own print files quickly and easily with a large selection of different templates, symbols and formats.

**i** Web code: #2016



## Clearly arranged home page

The intuitively arranged home page provides you with a quick start guide of your recent projects and lets you know about the latest updates.

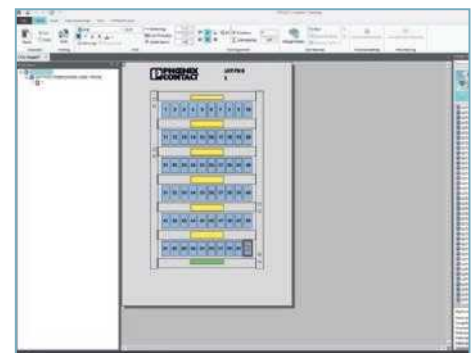

## High-performance marking tool

Create the right markings for your projects. PROJECT complete controls all marking systems from Phoenix Contact.

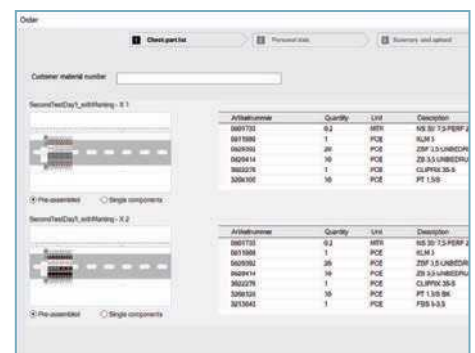

## Direct web connection

Transmit your project to the Phoenix Contact home page at the push of a button and start your order without losing time.



Detailed information and additional approvals can be found at: [phoenixcontact.com/products](http://phoenixcontact.com/products)

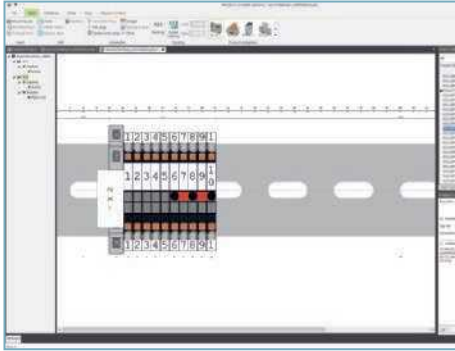

### Intuitive interface

PROJECT complete offers you an intuitively designed user interface. Customize the menu bars for your individual needs.

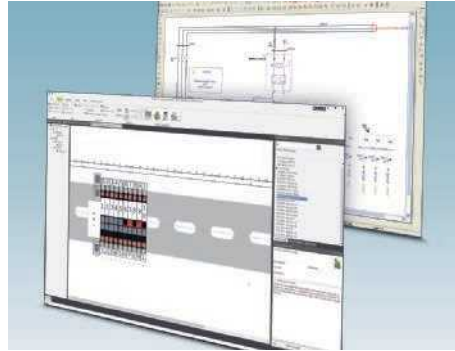

### Perfect interfaces

Import projects directly from electrical design planning. PROJECT complete has interfaces to the popular CAE systems.

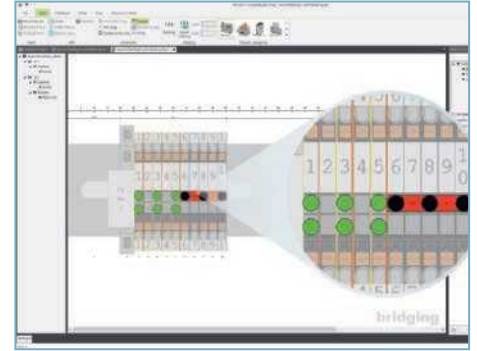

### Intelligent functions

PROJECT complete automates many work steps. Manually bridging or planning individual markings is no longer necessary.

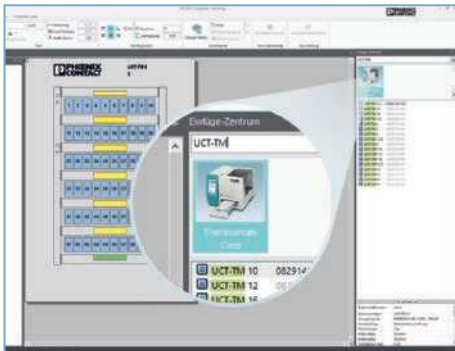

### Optimized search function

The intelligent item search selects your desired material using filters and ensures the perfect solution for your application.

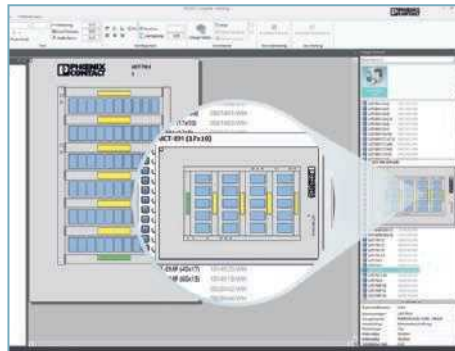

### Time-saving template preview

In the template preview, you can see the division of a material immediately and thus find the right product faster.

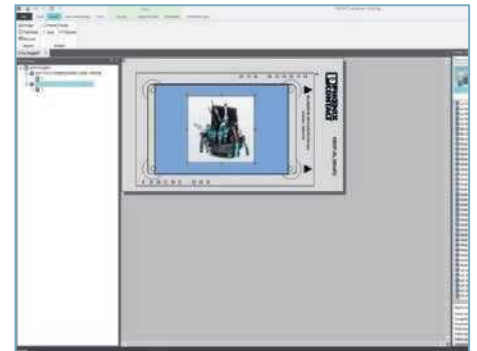

### Importing image data

PROJECT complete processes different file formats for the individual design of your marking.

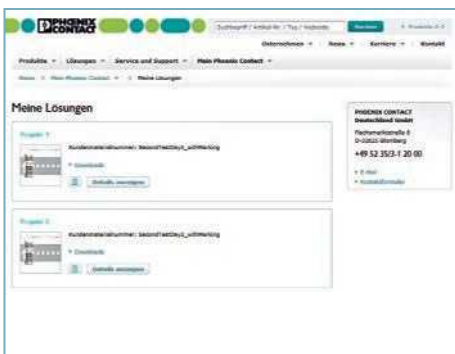

### Individualized solution area

All projects that you have created and sent with PROJECT complete are available for ordering in your solution area.

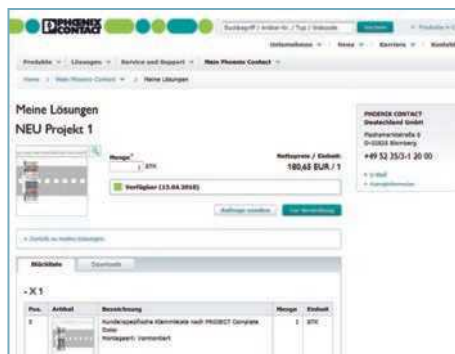

### Immediate price calculation

Receive a solution that meets your individual conditions and the item availability for your project without delay.

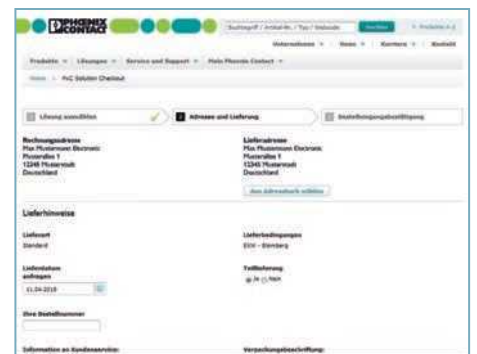

### Direct ordering option

Order your projects online without any intermediate steps and track the status of your delivery at any time.

# Conventional signal connection to process control systems

Phoenix Contact offers a complete range of products for signal connection to your control system. The conventional digital and analog field signals are routed to the switch rooms via terminal boxes and multicore cables. Here, marshaling and distribution takes place using signal conditioners for intrinsically safe and non-intrinsically safe signals, e.g., with devices from the MACX or MINI Analog Pro series. In addition, field signals are also sent via signal couplers to the input/output cards of the distributed control system.



## Certified safety relays

The safety relays offer solutions from emergency stop monitoring right up to coupling to failsafe controllers. This means that both ESD and F&G applications can be implemented in accordance with IEC 61508 and IEC 61511.



## Intrinsically safe I/Os

The intrinsically safe I/Os connect input and output signals to your network or bus system in potentially explosive areas.



## Surge protection for pipelines

Solutions from Phoenix Contact offer you reliable protection of your pipelines at any pipe transition point, thus ensuring longer maintenance intervals and longer operating times.





## Your advantages

- ✓ Compact design enables high packing density and thus saves space in control cabinets
- ✓ Innovative connection technologies shorten the installation time and make start-up easier
- ✓ Surge protection and transparent error diagnosis from the field signal to the I/O card using safety relays and signal conditioners increase the availability of your system and decrease maintenance work



### Surge protection

In order to ensure high system availability, the distributed control system requires optimal protection. This optimal protective function is achieved using surge protection for all input and output signals.



### Signal processing

Phoenix Contact offers extensive solutions for coupling a range of signals from the field level to distributed control systems.



### Termination boards and cables

VARIOFACE wiring interface offers a wide and varied range of standardized interface modules for connecting single wires at the sensor and actuator level to the controller in industrial applications.

# Reliable signal availability in the process industry

## PSRmini

As a specialist in the process industry, you rank compatibility and reliability among the primary requirements for your systems and components.

We would therefore like to introduce you to our highly compact, safe coupling relays for electrical isolation and power adaptation.

Adapted to the relevant distributed control systems and special requirements of your industry, we offer SIL-certified coupling modules for emergency shutdown and fire and gas applications.

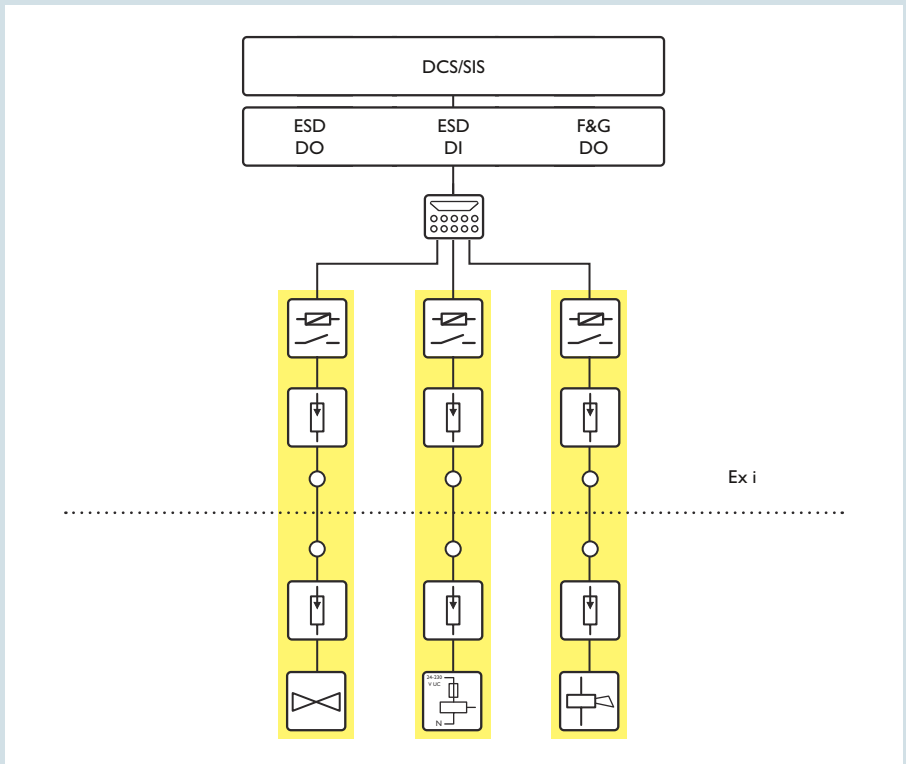

## Each signal is reliably available

### Safe shutdown

Thanks to their redundancy and force-guided contacts, the coupling relays for safe shutdown ensure that every command from your SIS is implemented. Safe switching is possible up to SIL 3.

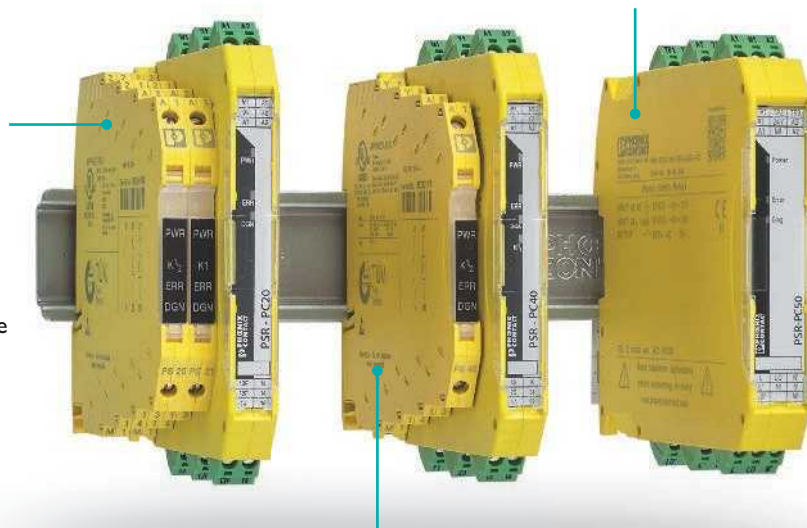

### Safe switch-on

Ensures safe activation at any time, thanks to comprehensive monitoring of the load side for open and short circuits.



### Safe shutdown with interlocking

The internal lock prevents the system from being switched on again in the event of an error.



### Diagnostics technologies

The PSRmini coupling relays feature innovative diagnostics technologies. This lets them reduce to a minimum the necessary hardware and the time for the SIL-relevant proof test required as standard.

### PSRmini: Highly compact, safe coupling relays for the process industry

 Web code: #0507 												
	Type Order No.	PSR-PS20 2700356	PSR-PS21 2700357	PSR-PS22 2702524	PSR-PS40 2700398	PSR-PC20 2700577	PSR-PC40 2700588	PSR-PC32 2700581	PSR-PC50 2904664	PSR-PC51 2702522	PSR-PC52 1017062	
Nominal voltage	24 V DC					24 V DC	24...230 V	24 V DC	24 V DC			
Applications	Safety-related shutdown (emergency shutdown)							Safety-related activation (fire and gas)				
N/O contact	1		1	1	1	2	2	1	1			
Signal contacts	1NC / 1DO		1 NC	1 DO	1NC / 1DO	1 DO	1 NC	1 DO	1 NC			
<b>Diagnostics technologies</b>												
Visual via LED	●		●	●	●	●	●	●	●			
Active error acknowledgment via A1	●		●	–	●	●	–	●	●			
Measurement on the device	●		●	–	●	–	●	●	●			
Self-monitoring with interlocking	–		–	●	–	●	–	–	–			
Overall width	6.8 mm				12.5 mm			17.5 mm				
Approvals	ATEX, IECEx, G3, GL, SIL, UL						ATEX, IECEx, SIL, UL	ATEX, IECEx, GL, SIL, UL	ATEX, IECEx, GL, G3, SIL, UL			

### PSRclassic: Conventional safe coupling relays for the process industry

 Web code: #1548 					
	Type Order No.	PSR-FSP 2981978	PSR-FSP/2x1 2986960	PSR-FSP2/2x1 2986575	PSR-ESP4 2981020
Nominal voltage	24 V DC				
Applications	Safety-related shutdown (emergency shutdown)				
N/O contact	1		2		12
N/C contact	1		1		1
<b>Diagnostics technologies</b>					
Measurement on the device	●		●		–
Self-monitoring with interlocking	–		–		●
Overall width	17.5 mm			22.5 mm	
Approvals	SIL, UL		SIL, UL		SIL, UL

Detailed information and additional approvals can be found at: [phoenixcontact.com/products](http://phoenixcontact.com/products)

# Conventional signal connection to distributed control systems

## Inline: Reliable up to Ex zone 2

Automation for potentially explosive areas in accordance with the European directive ATEX, international directive IECEx and US directive UL.

The Inline I/O system enables the recording and output of signals from Zone 0 and 1. A separate feed-in terminal provides standardized isolation of Ex and non-Ex components.

The blue housing color signals electrical intrinsic safety in accordance with ATEX. In this type of protection, the generation of sparks in the case of an error is prevented using various measures. The device is ruled out as an ignition source in hazardous areas.

**i** Web code: #1244

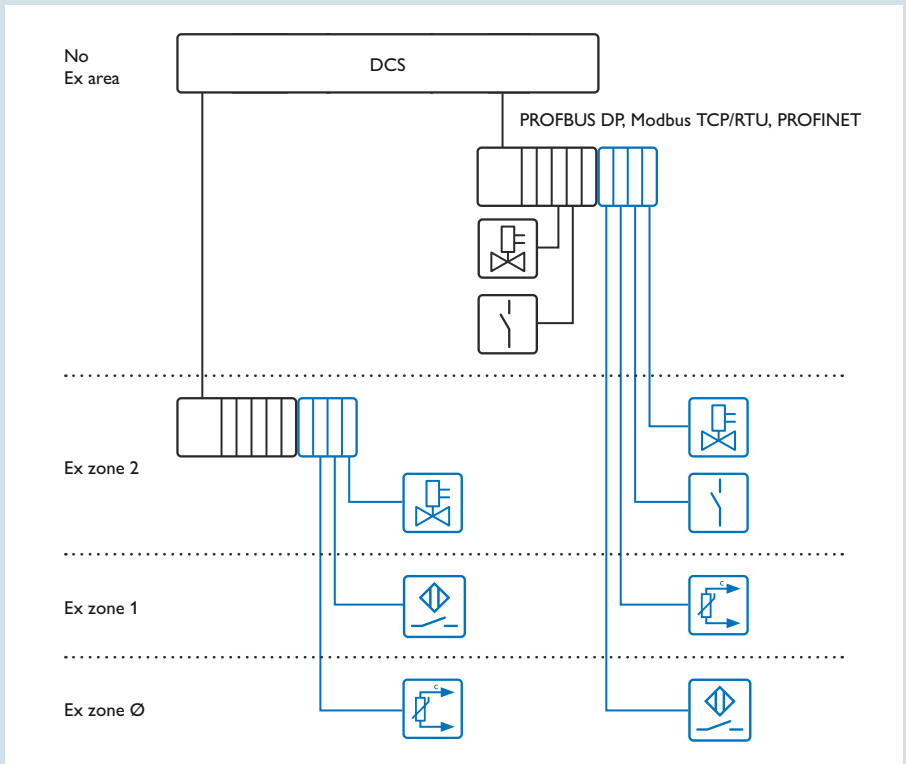

## Intrinsically safe I/Os for the Ex area

### Ex i analog input/output

Thanks to two current ranges for input and output as well as an input voltage range from 0 to 10 V, this terminal block can be used universally.

### Ex i temperature input

The temperature input terminal supports standard thermocouple sensors and commercially available resistive temperature-measuring devices.



### Ex i power supply

The power supply indicates the current status over several control displays. The supply terminal can distinguish between "voltage present", "high load range" and "overload".

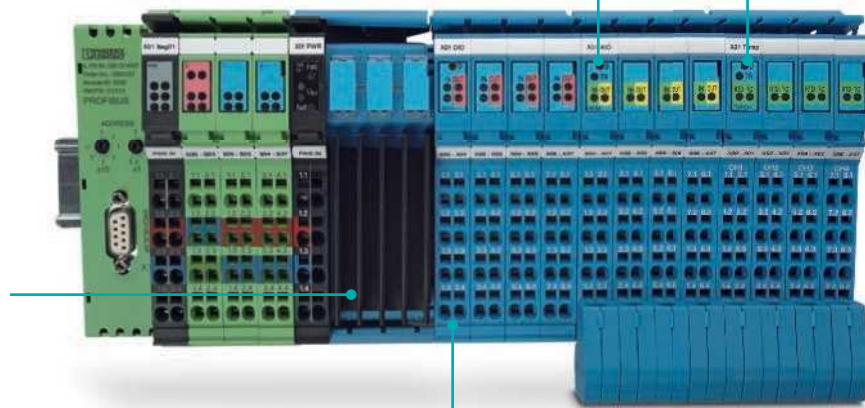









### Ex i digital input/output







The digital I/O terminal block supports inputs for NAMUR proximity switches and mechanical contacts, outputs for intrinsically safe solenoid valves, audible alarm indicators, and signal lamps.

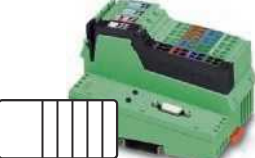
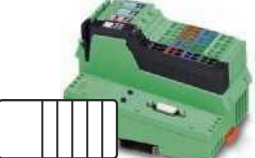

## Feed-in terminal, DIO module, AIO module, and TEMP module

				
	<b>Feed-in terminal</b>	<b>DIO module (configurable)</b>	<b>AIO module (configurable)</b>	<b>TEMP module (configurable)</b>
Type Order No.	IB IL EX-IS PWR IN-PAC 2869910	IB IL EX-IS DIO 4/NAM-PAC 2869911	IB IL EX-IS AIO 4/EF-PAC 2869912	IB IL EX-IS TEMP 4 RTD/TC-PAC 2869913
	 Web code: #2006	 Web code: #2006	 Web code: #2006	 Web code: #2006
Function	Power module	4 digital inputs/outputs with NAMUR function (EN 60447-5-6)	4 analog inputs/outputs; Output: 0/4 ... 20 mA; Input: 0 ... 10 V, 0/4 ... 20 mA	4 analog inputs; RTD (Pt, Ni respectively DIN 100, 200, 500, 1000); TC (J, K, E, R, S, T)
Ambient temperature	-25°C ... 60°C	-25°C ... 60°C	-25°C ... 60°C	-25°C ... 60°C
Approvals	ATEX, IECEx, UL	ATEX, IECEx, UL	ATEX, IECEx, UL	ATEX, IECEx, UL
ATEX	II 3G Ex nA IIC T4 Gc	II 3(1)GD Ex nA [ja Ga Da] IIC T4 Gc		
IECEx	Ex nA IIC T4 Gc	Ex nA [ja Ga Da] IIC T4 Gc		
UL (USA/Canada)	Class I, Div. 2, Groups A, B, C, D, T4	Installed Class I, Div. 2, Groups A, B, C, D Connected with Class I/II, Division 1, Groups A, B, C, D, E, F, G		
Diagnostic functions	Overload	Single-channel diagnostics	Single-channel diagnostics	Single-channel diagnostics
Connection technology Analog sensors	–	–	2-, 3-conductor	2-, 3-conductor

## Isolator terminal and bus coupler

				
	<b>Isolator terminal</b>	<b>Modbus RTU bus coupler</b>	<b>PROFIBUS DP bus coupler</b>	<b>Modbus TCP bus coupler</b>
Type Order No.	IB IL EX PWR-ISO-PAC 2869909	IL MOD BK DI8 DO4-PAC 2878696	IL PB BK DI8 DO4/EF-PAC 2692322	IL ETH BK DI8 DO4 2TX-PAC 2703981
	 Web code: #2006	 Web code: #2005	 Web code: #2005	 Web code: #2005
Function	Use between non-intrinsically safe Inline I/O expansion and the intrinsically safe Inline power supply	Onboard IOs: 4 DO, 8 DI 1.2 kbps ... 115.2 kbps	DP/V1 slave Onboard IOs: 4 DO, 8 DI 9.6 kbps ... 12 Mbps	Onboard IOs: 4 DO, 8 DI
Ambient temperature	-25°C ... 60°C	-25°C ... 60°C	-25°C ... 60°C	-25°C ... 60°C
Approvals	ATEX, IECEx, UL	ATEX, GL, UL	ATEX, GL, UL	ATEX, GL, UL
ATEX	II 3G Ex ec IIC T4 Gc	II 3 G Ex nA IIC T4 Gc X	II 3 G Ex nA IIC T4 Gc X	II 3 G Ex nA IIC T4 Gc X
IECEx	Ex nA IIC T4 GcX	–	–	–
UL (USA/Canada)	Class I, Div. 2, Groups A, B, C, D	UL 508	UL 508	Class I, Div. 2, Groups A, B, C, D
Diagnostic functions	–	Short circuit/overload IOs	Short circuit/overload IOs	Short circuit/overload IOs

Detailed information and additional approvals can be found at: [phoenixcontact.com/products](http://phoenixcontact.com/products)

# Products for lightning and surge protection

## Solutions for lightning protection and equipotential bonding on pipelines

In pipeline construction, pipes are assembled in segments and electrically isolated from one another in order to provide effective cathodic corrosion protection. It is necessary that the pipelines be routed with insulation from the ground potential due to the cathodic corrosion protection systems (KKS). This results in special requirements for lightning protection equipotential bonding. Direct grounding of the metallic pipe parts causes high fault current of the KKS. For this reason, it is necessary to ground the pipeline segments indirectly. Isolating spark gaps are used for this purpose.

The surge voltage protection modules must be selected according to system requirements and the grounding concept. This is only a schematic view.

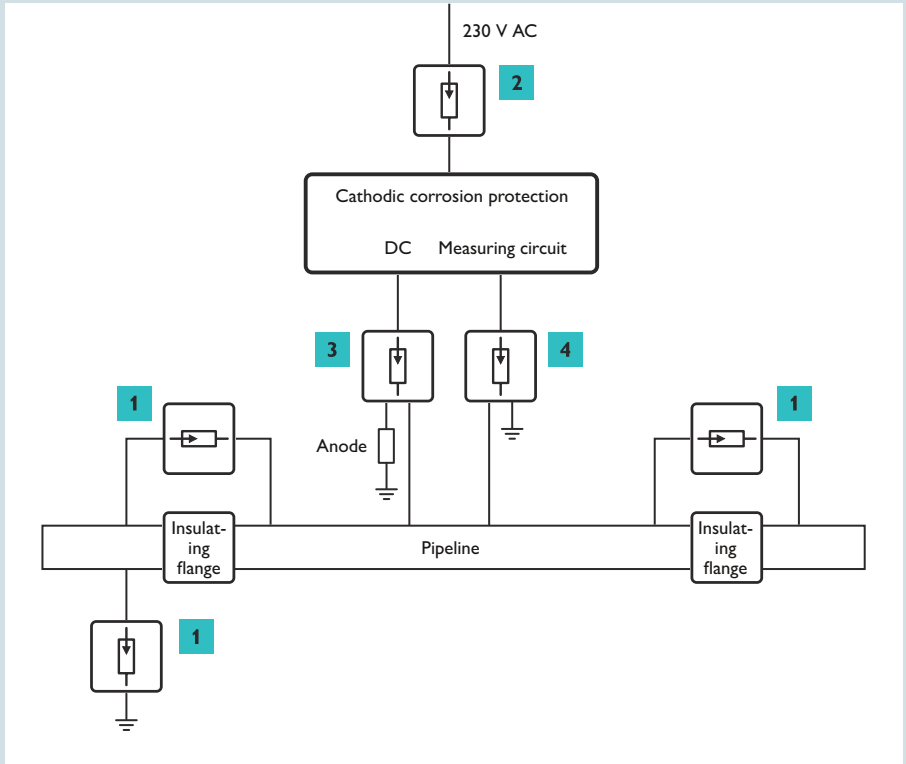

### Protecting an insulating flange

The isolating spark gap protects against damage to insulating flanges, which are vital for the segmentation of the pipeline. In the event of surge voltage, the isolating spark gap becomes low resistant and bypasses the insulation between the individual pipeline segments. The isolating spark gap discharges the surge voltage to ground at defined pipeline sections.



### Combining current carrying capacity









The FLT isolating spark gap is characterized by its high discharge capacity and very low sparkover voltage. The product and accessories have been optimized for use with the most popular insulating kits for pipeline flanges.



### Taking equipotential bonding into consideration

Consideration should be given to surge protection and equipotential bonding as early as the planning stage. Insulating flanges act as connecting elements between the individual pipe segments. It is important to provide indirect equipotential bonding here.

## Isolating spark gap, type 1 + 2 arrester combination, type 1/2 combination arrester, and surge protective device

					
		1	2	3	4
		Isolating spark gap	Arrester combination Type 1+2	Combination arrester Type 1/2	Surge protective device
Type	Order No.	FLT-ISG-100-EX <a href="#">2905579</a> FLT-ISG-PL-11 <a href="#">2905584</a> FLT-ISG-PL-42 <a href="#">2905756</a> FLT-ISG-BR-11 <a href="#">2905580</a> FLT-ISG-BR-62 <a href="#">2905765</a> FLT-ISG-CA-100 <a href="#">2905589</a> FLT-ISG-CA-300 <a href="#">2905591</a> FLT-ISG-PL-26 <a href="#">2905745</a> FLT-ISG-BR-26 <a href="#">2905757</a> FLT-ISG-CA-300 <a href="#">2905591</a>	FLT-SEC-T1+T2-1C-350/25-FM <a href="#">2905465</a>	VAL-MS-T1/T2 48/12.5 ST <a href="#">2801242</a>  DK-BIC-35 <a href="#">2749880</a>	TTC-6P-2-HC-... ...24DC-UT-I <a href="#">2906811</a> ...M-24DC-UT-I <a href="#">2906743</a> ...24DC-PT-I <a href="#">2906817</a> ...M-24DC-PT-I <a href="#">2906755</a>
		 Web code: <a href="#">#0109</a>	 Web code: <a href="#">#0116</a>	 Web code: <a href="#">#2019</a>	 Web code: <a href="#">#1319</a>
Approvals		ATEX, IECEx, UL	GL, UL	GL, UL	G3, GL, SIL, UL

Detailed information and additional approvals can be found at: [phoenixcontact.com/products](http://phoenixcontact.com/products)

# Products for lightning and surge protection







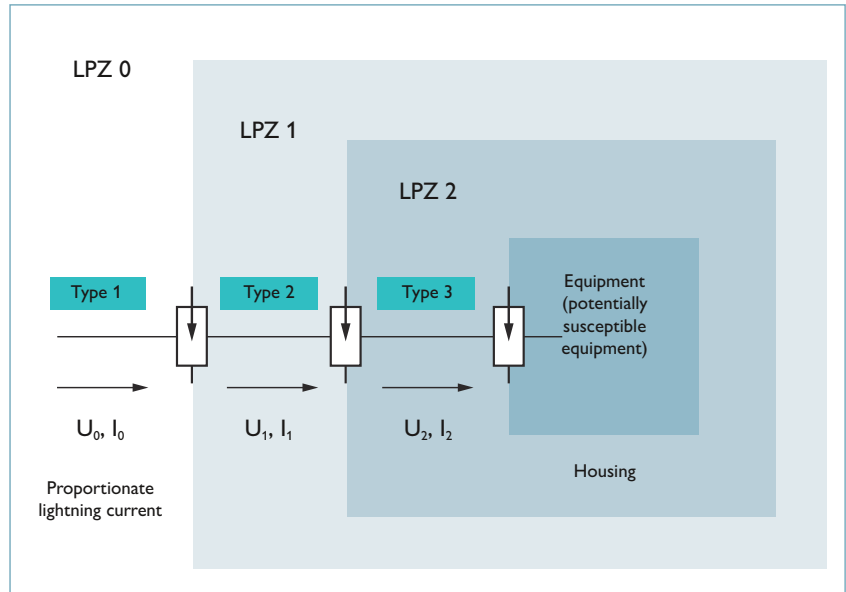





## Solutions for surge protection in a process system

The system to be protected is divided into lightning protection zones (LPZs). The appropriate lightning and surge protective devices must be installed at the boundaries between zones.

This applies to lines in the areas of power supply, measurement and control technology, data processing, and telecommunications as well as to transmitter and receiver devices.









## Surge protection for power supplies









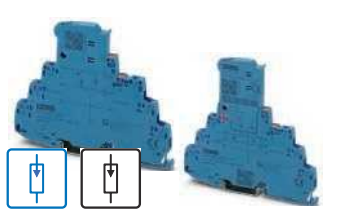

					
					
		<b>Type 1 surge protective device</b>	<b>Type 1 + type 2 surge protective device</b>	<b>Type 2 surge protective device</b>	<b>Type 3 device protection</b>
Type	Order No.	FLT-SEC-P-T1-... ...3S-350/25-FM <b>2905421</b> ...3C-350/25-FM <b>2905419</b>  FLT-SEC-H-T1-... ...1C-264/25-FM <b>2801615</b> ...3C-264/25-FM <b>2905871</b>	FLT-SEC-T1+T2-... ...3S-350/25-FM <b>2905470</b> ...3C-350/25-FM <b>2905469</b> ...3IT-350/25-FM <b>1044386</b> ...2IT-350/25-FM <b>1044388</b>	VAL-SEC-T2-... ...3S-350-FM <b>2905340</b> ...3C-350-FM <b>2905339</b> ...3C-440-FM <b>2909968</b>	PLT-SEC-T3-... ...230-FM-PT <b>2907928</b> ...24-FM-PT <b>2907925</b> ...230-FM-UT <b>2907919</b> ...24-FM-UT <b>2907916</b>
		 Web code: <b>#0646</b>	 Web code: <b>#0116</b>	 Web code: <b>#0117</b>	 Web code: <b>#1777</b>
Approvals		GL, UL	GL, UL	GL, UL	GL, UL



## Surge protection for information and data technology

				
				
		<b>Surge protective device for Gigabit Ethernet, Token Ring, FDDI/CDDI, ISDN, DS1</b>	<b>Surge protective device for 19" applications</b>	
Type	Order No.	DT-LAN-CAT.6+ <a href="#">2881007</a>	D-LAN-19"-24 <a href="#">2838791</a> D-LAN-19"-20 <a href="#">2880134</a> D-LAN-19"-16 <a href="#">2880147</a> D-LAN-19"-12 <a href="#">2880150</a>	
		 Web code: <a href="#">#0145</a>	 Web code: <a href="#">#0145</a>	
Approvals		UL	-	













## Surge protection for MCR technology

				
		 		
		<b>Surge protection for Ex i applications</b>	<b>Surge protection for non-Ex i applications</b>	<b>Surge protection field devices</b>
Type	Order No.	TTC-6-... ...1x2-M-EX-24DC-UT-I <a href="#">2906820</a> ...2x1-M-EX-24DC-UT-I <a href="#">2906821</a>  TTC-6P-... ...1x2-M-EX-24DC-UT-I <a href="#">2906824</a> ...2x1-M-EX-24DC-UT-I <a href="#">2906825</a>  TTC-6-3-HF-F-M-EX-... ...24DC-UT-I <a href="#">2906823</a> ...12DC-UT-I <a href="#">2906822</a>  TTC-6-FMRS-PT <a href="#">2907811</a>	TTC-6P-1X2-M-... ...24DC-UT-I <a href="#">2906738</a> ...24DC-PT-I <a href="#">2906750</a>  TTC-6-1X2-... ...24DC-UT <a href="#">2906798</a> ...24DC-PT <a href="#">2906804</a>  TTC-6-FMRS-UT <a href="#">2907810</a> TTC-6-FMRS-PT <a href="#">2907811</a>	Ex i: S-PT-EX(I)-24DC-1/2" <a href="#">2882572</a>  Ex i/Ex d: S-PT-EX-24DC-1/2" <a href="#">2800035</a> S-PT-2XEX-24DC-1/2" <a href="#">2800041</a> S-PT-4-EX-24DC-1/2" <a href="#">2800037</a>
		 Web code: <a href="#">#1322</a>	 Web code: <a href="#">#1389</a>	 Web code: <a href="#">#0292</a>
Approvals		ATEX, IECEx, G3, GL, SIL, UL	G3, GL, SIL, UL	ATEX, IECEx, G3, GL, SIL,













Detailed information and additional approvals can be found at: [phoenixcontact.com/products](http://phoenixcontact.com/products)



## Products for intrinsically safe and non-intrinsically safe circuits

					
					
		<b>Display of loop-powered HART master</b>	<b>Surge protection Field devices</b>	<b>Signal conditioners/ Repeater power supplies</b>	<b>Signal conditioners/ Repeater power supplies</b>
Type	Order No.	FA MCR-DS-I-I-OLP 2908781 FA MCR-EX-DS-I-I-OLP 2908800	Ex i: S-PT-EX(I)-24DC-1/2" 2882572  Ex i/Ex d: S-PT-EX-24DC-1/2" 2800035 S-PT-2XEX-24DC-1/2" 2800041 S-PT-4-EX-24DC-1/2" 2800037	MACX MCR-... ...UI-UI-NC 2811446 ...UI-UI-UP-NC 2811297 ...SL-RPSSI-I 2865955 ...SL-RPSSI-2I 2924825 ...SL-RPSSI-2I-2I 2904089	MINI MCR-... ...2-UI-UI 2902037 ...2-I-I 2901998 ...2-RPSSI-I 2902014 ...2-RPSSI-O-2I 2905628
		 Web code: #1140	 Web code: #0292	 Web code: #1141	 Web code: #0492
Approvals		ATEX, IECEx, G3, GL, SIL, UL	ATEX, IECEx, G3, GL, SIL	ATEX, G3, GL, SIL, UL	ATEX, G3, GL, UL

## Products for non-intrinsically safe circuits

					
					
		<b>System cabling uni</b>	<b>Surge protection</b>	<b>Bus couplers Inline I/O</b>	<b>Head-mounted temperature transducer</b>
Type	Order No.	Termination board: VIP-2/SC/FLK10 2315010  System cable: FLK 10/EZ-DR/ 200/KONFEK 2299233  Free cable end: CABLE-FLK10/OE/0,14/ 2,0M 2904076	TTC-6P-1X2-M-... ...24DC-UT-I 2906738 ...24DC-PT-I 2906750  TTC-6-1X2-... ...24DC-UT 2906798 ...24DC-PT 2906804	PROFINET: IL PN BK DI8 DO4 2TX-PAC 2703994  PROFIBUS DP: IL PB BK DI8 DO4/EF-PAC 2692332  IB IL AI 8/SF-PAC 2861412 IB IL AI 2-HART-PAC 2862149	MCR-... ...SL-HT-PT 100-I 2864516 ...FL-HT-T-I 2864529
		 Web code: #2024	 Web code: #1389	 Web code: #1154	 Web code: #1140
Approvals		UL	G3, GL, SIL, UL	ATEX, UL	ATEX, UL

Detailed information and additional approvals can be found at: [phoenixcontact.com/products](http://phoenixcontact.com/products)







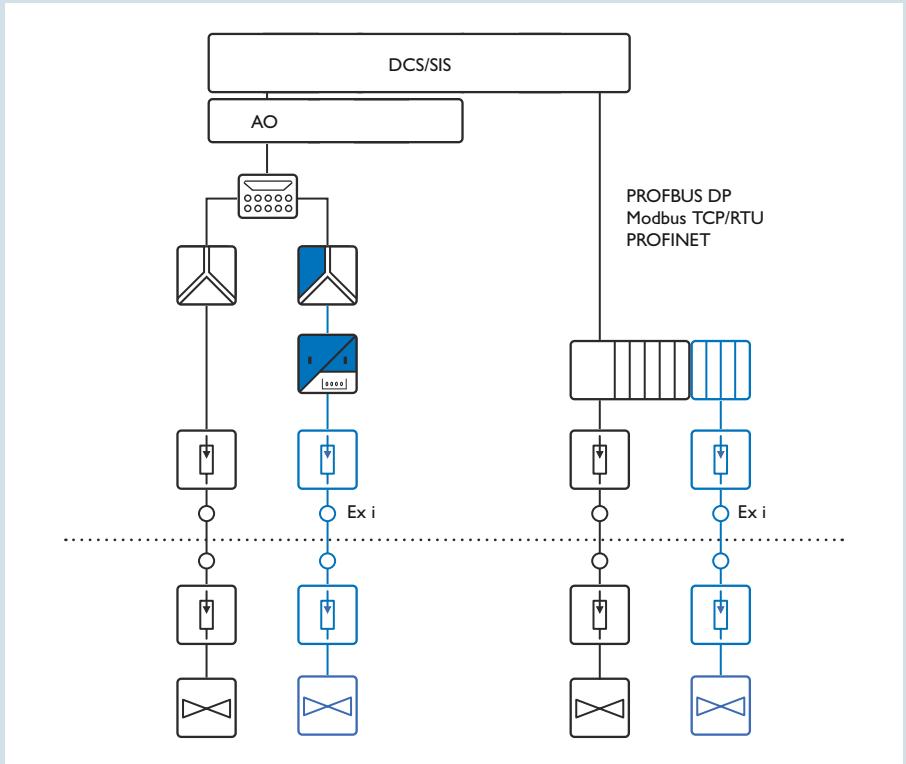





# Products for conventional signal connection

## Solutions for analog output signal processing













Phoenix Contact offers comprehensive solutions for connecting analog output signals from the field level to process control systems. They include measuring transducers and signal conditioners, such as the Inline I/O remote control system. Suitable surge protection and system cabling solutions complete the turn-key solution.











## Products for intrinsically safe circuits

		 	 	 	 
		Output signal conditioners	Inline I/O intrinsically safe and power supply unit	Surge protection	Surge protection Field devices
Type	Order No.	MACX MCR-EX-... ...SL-IDS-I 2865405 ...SL-IDS-I-SP 2924032	Ex i: IB IL EX-IS AIO 4/EF-PAC 2869912 IB IL EX PWR-ISO-PAC 2869909 IB IL EX-IS PWR IN-PAC 2869910	Pluggable version: TTC-6P-1X2-M-EX-24DC-UT-I 2906824  TTC-6-2X1-M-EX-24DC-UT-I 2906821	Ex i: S-PT-EX(I)-24DC 2880671  Ex i/Ex d: S-PT-EX-24DC 2800034 S-PT-2XEX-24DC 2800040 S-PT-4-EX-24DC 2800036
		 Web code: #1142	 Web code: #2006	 Web code: #1389	 Web code: #0292
Approvals		ATEX, IECEx, G3, GL, SIL, UL	ATEX	ATEX, IECEx, G3, GL, SIL, UL	ATEX, IECEx, G3, GL, SIL

## Products for intrinsically safe and non-intrinsically safe circuits

					
					
		<b>Display of loop-powered HART master</b>	<b>Surge protection Field devices</b>	<b>Output signal conditioners</b>	<b>Output signal conditioners</b>
Type	Order No.	FA MCR-... ...DS-I-I-OLP <a href="#">2908781</a> ...EX-DS-I-I-OLP <a href="#">2908800</a>	Ex i: S-PT-EX(I)-24DC-1/2" <a href="#">2882572</a>  Ex i/Ex d: S-PT-EX-24DC-1/2" <a href="#">2800035</a> S-PT-2XEX-24DC-1/2" <a href="#">2800041</a> S-PT-4-EX-24DC-1/2" <a href="#">2800037</a>	MACX MCR-... ...UI-UI-NC <a href="#">2811446</a> ...UI-UI-UP-NC <a href="#">2811297</a> ...SL-IDS-I <a href="#">2865971</a>	MINI MCR-... ...2-UI-UI <a href="#">2902037</a> ...2-I-I <a href="#">2901998</a> ...SL-IDS-I-I <a href="#">2905577</a> ...SL-I-I <a href="#">2864406</a>
		 Web code: <a href="#">#1140</a>	 Web code: <a href="#">#0292</a>	 Web code: <a href="#">#1141</a>	 Web code: <a href="#">#0492</a>
Approvals		ATEX, IECEx, G3, GL, SIL, UL	ATEX, IECEx, G3, GL, SIL	ATEX, G3, GL, SIL, UL	ATEX, G3, GL, UL













## Products for non-intrinsically safe circuits

					
					
		<b>System cabling uni</b>	<b>Surge protection</b>	<b>Inline I/O bus coupler</b>	
Type	Order No.	Termination board: VIP-2/SC/D 9SUB/M <a href="#">2315117</a>  System cable: CABLE-D 9SUB/B/S/200/ KONFEK/S <a href="#">2302010</a>  Free cable end: CABLE-D- 9SUB/F/OE/0,25/ S/2,0M <a href="#">2926043</a>	TTC-6P-1X2-M-... ...24DC-UT-I <a href="#">2906738</a> ...24DC-PT-I <a href="#">2906750</a>  TTC-6-1X2-... ...24DC-UT <a href="#">2906798</a> ...24DC-PT <a href="#">2906804</a>	PROFINET: IL PN BK DI8 DO4 2TX-PAC <a href="#">2703994</a>  PROFIBUS DP: IL PB BK DI8 DO4/EF-PAC <a href="#">2692332</a>  Modbus/RTU: IL MOD BK DI8 DO4-PAC <a href="#">2878696</a>  IB IL AO 1/SF-PAC <a href="#">2861315</a>	
		 Web code: <a href="#">#2024</a>	 Web code: <a href="#">#1389</a>	 Web code: <a href="#">#1154</a>	
Approvals		UL	G3, GL, SIL, UL	ATEX, UL	















Detailed information and additional approvals can be found at: [phoenixcontact.com/products](http://phoenixcontact.com/products)



## Products for intrinsically safe and non-intrinsically safe circuits

		 	 	 	 
		Digital / NAMUR signal conditioners	Digital / NAMUR signal conditioners	Bus couplers Inline I/O	NAMUR switches
Type	Order No.	MACX MCR-SL-... ...2NAM-RO 2865049 ...NAM-2RO 2865010 ...2NAM-T 2865036 ...NAM-2T 2865023	MINI MCR-2-NAM-... ...2RO 2902004 ...2RO-PT 2902005 ...2RNO 2864105 ...2RNO-SP 2810269	PROFINET: IL PN BK D18 DO4 2TX-PAC 2703994  PROFIBUS DP: IL PB BK D18 DO4/EF-PAC 2692332  Modbus/RTU: IL MOD BK D18 DO4-PAC 2878696  IB IL 24 DI 32/HD-PAC 2862835	PLC-SC-EIK 1-SVN 24P/P 2982663  PLC-PT-EIK 1-SVN 24P/P 2900397
		 Web code: #1141	 Web code: #0492	 Web code: #1154	 Web code: #1937
Approvals		ATEX, G3, GL, SIL, UL	ATEX, G3, GL, SIL, UL	ATEX, UL	UL

## Products for non-intrinsically safe circuits

 	 	 	 	 
System cabling uni	Surge protection for signals with common connection	Sensor coupling relays	Safety relays	Motor and machine management
Termination board: VIP-3/SC/D50SUB/F 2315201  System cable: CABLE-D50SUB/S/S/200/ KONFEK/S 2305703  Free cable end: CABLE-D-50SUB/M/ OE/0,25/S/2,0M 2926674	TTC-6P-2X1-F-M-... ...24DC-UT-I 2906784 ...24DC-PT-I 2906794	PLC-RSC-24DC/1AU/SEN 2966317 PLC-RSC-120UC/1AU/SEN 2966320 PLC-RSC-230UC/1AU/SEN 2966333	PSR-PC32 2700581	EMM 3-24DC/500AC-... ...16-IFS 2297523 ...IFS 2297497 ...90-EXM-IFS 2908602 ...160-EXM-IFS 2908603
 Web code: #2024	 Web code: #1389	 Web code: #0617	 Web code: #0507	 Web code: #1262
UL	G3, GL, SIL, UL	UL	G3, SIL	ATEX, UL

Detailed information and additional approvals can be found at: [phoenixcontact.com/products](http://phoenixcontact.com/products)







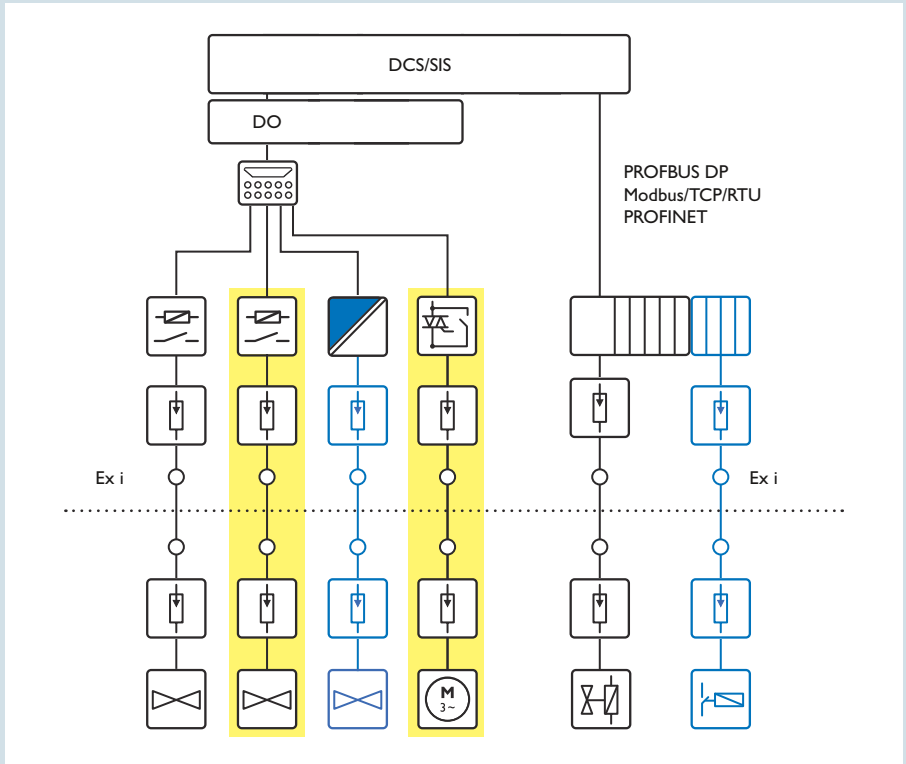





# Products for conventional signal connection

## Solutions for digital output signal processing

Phoenix Contact offers comprehensive solutions for connecting digital output signals from the process control level to the field level. They include coupling relays, solenoid drivers and safety relays, as well as the Inline I/O remote control system. Suitable surge protection and system cabling solutions complete the turn-key solution.









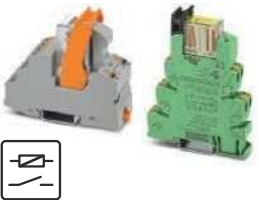
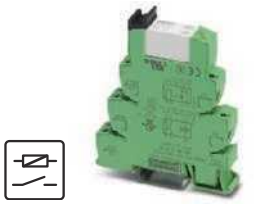
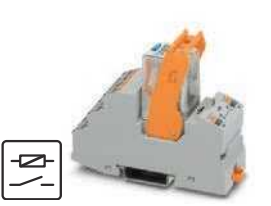

## Products for intrinsically safe circuits











		 	 	 	 
		Solenoid driver	Inline I/O intrinsically safe and power supply unit	Surge protection	Surge protection field devices
Type	Order No.	MACX MCR-EX-SL-SD-... ...24-48-LP 2865609 ...24-48-LP-SP 2924126 ...23-48-LFD 2924867	Ex i: IB IL EX-IS DIO 4/NAM-PAC 2869911  IB IL EX-IS PWR IN-PAC 2869910  IB IL EX PWR-ISO-PAC 2869909	Pluggable version: TTC-6P-1X2-M-EX-24DC-UT-I 2906824  TTC-6-2X1-M-EX-24DC-UT-I 2906821	Ex i: S-PT-EX(I)-24DC 2880671  Ex i/Ex d: S-PT-EX-24DC 2800034  S-PT-2XEX-24DC 2800040 S-PT-4-EX-24DC 2800036
		 Web code: #1142	 Web code: #2006	 Web code: #1389	 Web code: #1389
Approvals		ATEX, IECEx, G3, GL, SIL, UL	ATEX	ATEX, IECEx, G3, GL, SIL, UL	ATEX, IECEx, G3, SIL

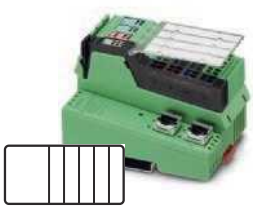

## Products for intrinsically safe and non-intrinsically safe circuits

				
<b>Force-guided coupling relays</b>	<b>Coupling relay actuator</b>	<b>Coupling relays</b>	<b>SIL coupling relay, emergency shutdown</b>	<b>SIL coupling relay, fire and gas</b>
PLC-RPT-24DC/2X21/FG <a href="#">2910537</a> PLC-RSC-24UC/2X21/FG <a href="#">2910536</a> RIF-1-RPT-LDP-24DC/2X21/FG <a href="#">2908215</a>	PLC-RSC-24DC/1-1/ACT <a href="#">2967109</a> PLC-OSC-24DC/24DC/2/ACT <a href="#">2966676</a> PLC-RSC-24DC/1/ACT <a href="#">2966210</a> PLC-OSC-24DC/24DC/2/ACT <a href="#">2966676</a>	RIF-0-RPT-24DC/21 <a href="#">2903370</a> RIF-1-RPT-LDP-24DC/2x21 <a href="#">2903334</a> RIF-2-RPT-LDP-24DC/4x21 <a href="#">2903308</a> RIF-4-RPT-LDP-24DC/3X21 <a href="#">2903278</a> RIF-4-RSC-LDP-24DC/3X21 <a href="#">2903288</a>	PSR-PS20 <a href="#">2700356</a> PSR-PC20 <a href="#">2700356</a> PSR-PS22 <a href="#">2702524</a> PSR-PC40 <a href="#">2700588</a>	PSR-PC50 <a href="#">2904664</a> PSR-PC51 <a href="#">2702522</a> PSR-PC52 <a href="#">1017062</a>
 Web code: <a href="#">#1937</a>	 Web code: <a href="#">#0618</a>	 Web code: <a href="#">#0695</a>	 Web code: <a href="#">#0507</a>	 Web code: <a href="#">#0507</a>
UL	G3, GL, UL	G3, GL, UL	ATEX, IECEx, G3, GL, SIL, UL	SIL, UL (Application submitted for ATEX, IECEx, GL)

## Products for intrinsically safe and non-intrinsically safe circuits

				
<b>System cabling uni</b>	<b>Coupling relays for Zone 2</b>	<b>Bus couplers Inline I/O</b>	<b>Surge protection for high-voltage loop signals</b>	<b>Safe motor starters</b>
Termination board: VIP-3/SC/FLK50 <a href="#">2315081</a> System cable: FLK 50/EZ-DR/200/KONFEK <a href="#">2289094</a> Free cable end: CABLE-FLK50/OE/0,14/200 <a href="#">2305376</a>	PLC-RSC-24DC/21-21/EX <a href="#">2909509</a> PLC-RSC-24DC/21HC/EX <a href="#">2909519</a> PLC-RPT-24DC/21/EX <a href="#">2909528</a> RIF-2-RPT-LDP-24DC/4X21/EX <a href="#">2909741</a> RIF-2-RPT-LV-120AC/4X21/EX <a href="#">2909740</a> RIF-2-RPT-LV-230AC/4X21/EX <a href="#">2909739</a>	PROFINET: IL PN BK DI8 DO4 2TX-PAC <a href="#">2703994</a> PROFIBUS DP: IL PB BK DI8 DO4/EF-PAC <a href="#">2692332</a> Modbus/RTU: IL MOD BK DI8 DO4-PAC <a href="#">2878696</a> IB IL 24 DO 32/HD-PAC <a href="#">2862822</a>	TTC-6P-2-HC-M-... ...24DC-UT-I <a href="#">2906743</a> ...24DC-PT-I <a href="#">2906755</a> TTC-6-2-HC-... ...24DC-UT-I <a href="#">2908438</a> ...24DC-PT-I <a href="#">2908439</a>	ELR H3-IES-SC-24DC/500AC-9 <a href="#">2900569</a> ELR H5-IES-SC-24DC/500AC-9 <a href="#">2900421</a> ELR H3-IES-SC-24DC/500AC-2 <a href="#">2900567</a> ELR H5-IES-SC-24DC/500AC-2 <a href="#">2900414</a>
 Web code: <a href="#">#2024</a>	 Web code: <a href="#">#0690</a>	 Web code: <a href="#">#1154</a>	 Web code: <a href="#">#1389</a>	 Web code: <a href="#">#1077</a>
UL	ATEX, IECEx, G3, UL	ATEX, UL	UL, G3, GL, SIL	ATEX, SIL, UL

Detailed information and additional approvals can be found at: [phoenixcontact.com/products](http://phoenixcontact.com/products)







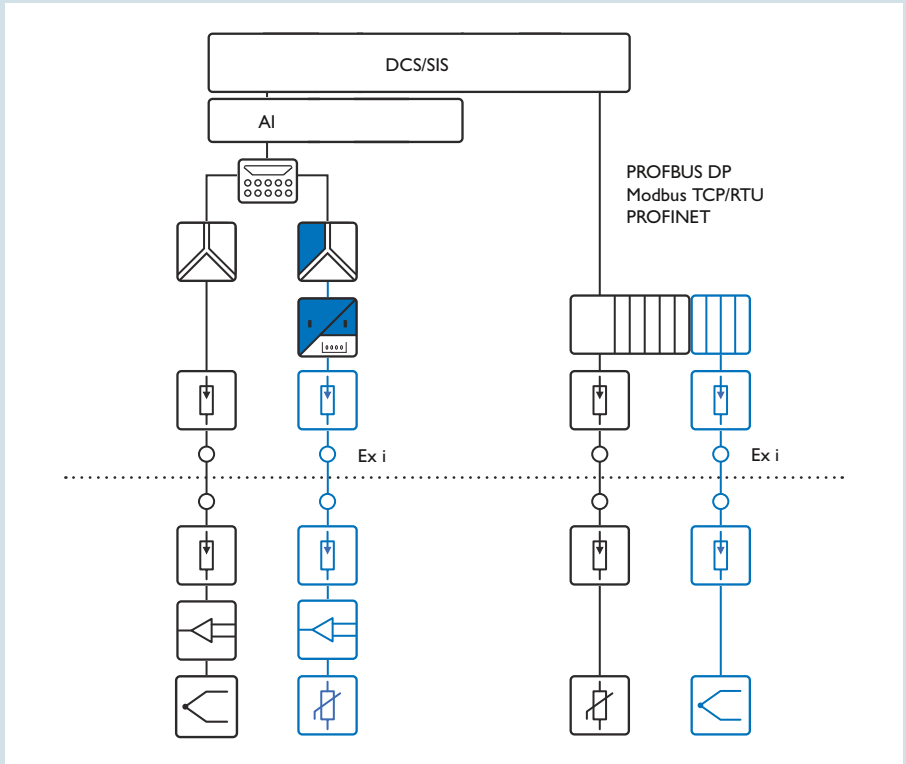





# Products for conventional signal connection

## Solutions for measured temperature value processing











Comprehensive solutions are available for connecting measured temperature values from the field level to process control systems. They include measuring transducers in a wide range of versions, as well as the Inline I/O remote control system. Suitable surge protection and system cabling solutions complete the turn-key solution.

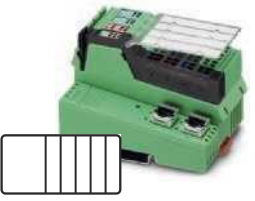











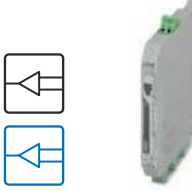

## Products for intrinsically safe circuits

		 	 	 	 
		Temperature measuring transducers	Inline I/O intrinsically safe and power supply unit	Surge protection	Surge protection Field devices
Type	Order No.	MACX MCR-EX-SL-RTD-I <a href="#">2865939</a> MACX MCR-EX-T-UI-UP <a href="#">2865654</a>	IB IL EX-IS ... ... TEMP4RTD/TC-PAC <a href="#">2869913</a> ... PWR IN-PAC <a href="#">2869910</a>  IB IL EX PWR-ISO-PAC <a href="#">2869909</a>	Plug: PT 4-EX(I)-24DC-ST <a href="#">2839253</a>  Base element: PT 4-EX(I)-BE <a href="#">2839486</a>  Alternative: LIT 4-24 <a href="#">2804678</a>	S-PT-EX(I)-24DC <a href="#">2880671</a> S-PT-EX-24DC <a href="#">2800034</a> S-PT-2XEX-24DC <a href="#">2800040</a> S-PT-4-EX-24DC <a href="#">2800036</a>
		 Web code: <a href="#">#1142</a>	 Web code: <a href="#">#2006</a>	 Web code: <a href="#">#1389</a>	 Web code: <a href="#">#1389</a>
Approvals		ATEX, IECEx, G3, GL, SIL, UL	ATEX	ATEX, IECEx, G3, SIL	ATEX, IECEx, G3, SIL

## Products for intrinsically safe and non-intrinsically safe circuits

					
					
		<b>Display of loop-powered HART master</b>	<b>Display with temperature, current and voltage input</b>	<b>Temperature measuring transducers</b>	<b>Bus couplers Inline I/O</b>
Type	Order No.	FA MCR-DS-I-I-OLP 2908781  Ex i: FA MCR-EX-DS-I-I-OLP 2908800	FA MCR-D-TUI-U-2REL-UP 2907064  Ex i: FA MCR-EX-D-TUI-UI-2REL-UP 2907216	MACX MCR-... ...SL-TC-I MACX MCR-... ...T-UIREL-UP  MINI MCR-2-... ...RTD-UI ...TC-UI ...T-2RO ...T-REL	PROFINET: IL PN BK DI8 DO4 2TX-PAC 2703994 PROFIBUS DP: IL PB BK DI8 DO4/EF-PAC 2692332  IB IL TEMP 2 RTD-PAC 2861328 IB IL TEMP 2 UTH-PAC 2861386
		 Web code: #1140	 Web code: #1140	 Web code: #1142, #0492	 Web code: #1154
Approvals		ATEX, IECEx, G3, GL, SIL, UL	ATEX, IECEx, G3, GL, SIL, UL	ATEX, G3, GL, UL	ATEX, UL

## Products for intrinsically safe and non-intrinsically safe circuits

					
					
		<b>System cabling uni</b>	<b>Surge protection for RTD</b>	<b>Loop-powered temperature transmitter</b>	<b>Head-mounted transducers</b>
Type	Order No.	Termination board: VIP-2/SC/D 9SUB/M2315117  System cable: CABLE-D 9SUB/B/S/200/ KONFEK/S 2302010  Free cable end: CABLE-D- 9SUB/F/OE/0,25/ S/2,0M 2926043	Connector: PT 4-5DC-ST 2839211  Base element: PT4-BE 2839402	Ex i: MACX MCR-TS-I-OLP 2908662  MACX MCR-EX-TS-I-OLP 2908660	Ex i: FA MCR-EX-HT-TS-I-OLP-PT 2908743  FA MCR-HT-TS-I-OLP-PT 2908742
		 Web code: #2024	 Web code: #1389	 Web code: #1140	 Web code: #1140
Approvals		UL	SIL, UL	ATEX, IECEx, G3, GL, SIL, UL	ATEX, IECEx, G3, GL, SIL, UL

Detailed information and additional approvals can be found at: [phoenixcontact.com/products](http://phoenixcontact.com/products)

# Products for conventional signal connection

## Solutions for applications with WirelessHART

Conventional analog field devices which are connected to non-HART-compatible process control systems can be extended easily and without needing to replace the existing control hardware by using WirelessHART networks. On field devices that are already hardwired, WirelessHART adapters can be used to connect to a WirelessHART/WLAN gateway. A wide range of parameterization and diagnostic functions can therefore be integrated into the existing system without having to stop the process.

The entire standard TRABTECH product range can be used to protect HART communication against overvoltages.

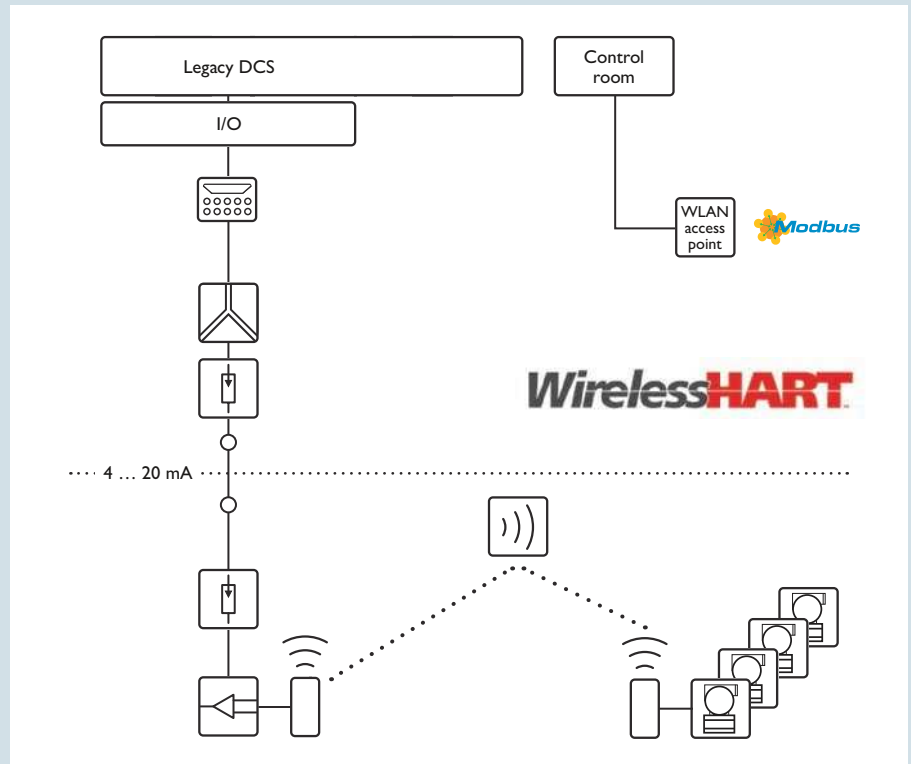

### Wireless HART

**i** Web code: #1132



#### WirelessHART/WLAN gateway

#### WirelessHART adapter:

Type	Order No.	RAD-WHG/WLAN-XD	2900178	RAD-WHA-1/2NPT	2900100
Description	Connects up to 250 WirelessHART field devices		Connects up to four HART-compatible or a conventional 4 ... 20 mA field device		
	Converts HART data to Modbus/TCP and HART IP		External or loop supply		
	Easy startup using integrated web server		Housing with IP65 degree of protection		
Approvals	ATEX, IECEx		ATEX, IECEx		

## Solutions for Ethernet applications with HART

The modular Ethernet HART multiplexer enables access to HART-compatible field instruments via familiar Ethernet-based fieldbuses such as PROFINET, Modbus/TCP, and HART IP. Each device has a separate HART master which can be connected to higher-level fast Ethernet network infrastructures. Up to 40 HART devices can be connected to existing configuration tools such as PACTware, SIMATIC PDM, Honeywell FDM, the HART OPC server or HART server. System operators therefore save time and money since configuration and calibration, e.g. partial stroke test, process monitoring or current loop tests, are controlled via Ethernet and everything can be performed during active operation.

All surge protection products are compatible with the HART protocol.

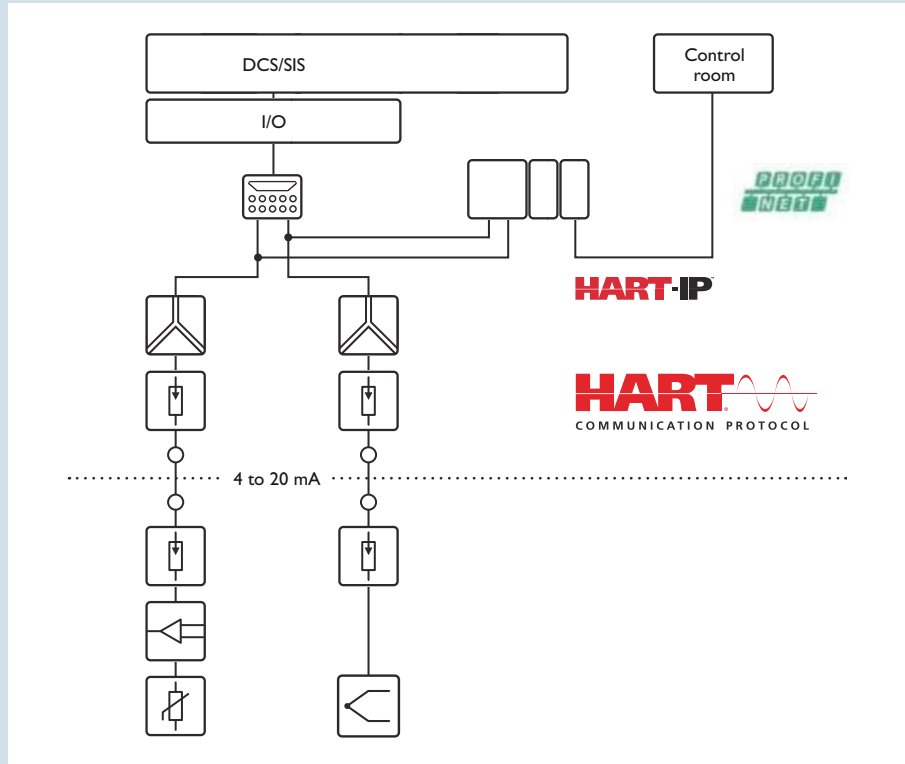

### Ethernet HART multiplexer

**i** Web code: [#1567](#)



#### Modular Ethernet HART multiplexer

Type	Order No.		
		GW PL ETH/UNI-BUS	<a href="#">2702233</a>
		GW PL ETH/BASIC-BUS	<a href="#">2702321</a>
		GW PL HART4-BUS	<a href="#">2702234</a>
		GW PL HART4-R-BUS	<a href="#">2702879</a>
		GW PL HART4-R-BUS	<a href="#">2702880</a>
		GW PL HART8-BUS	<a href="#">2702235</a>
		GW PL HART8+AI-BUS	<a href="#">2702236</a>
		GW PL DIO4-BUS	<a href="#">2702237</a>
Description		Modular design – up to 40 HART devices can be connected	
		Converts HART protocols to HART IP, Modbus/TCP or PROFINET	
		For the fastest possible data access, each HART connection has a separate HART master	
Approvals		ATEX, IECEx, G3	

Detailed information and additional approvals can be found at: [phoenixcontact.com/products](http://phoenixcontact.com/products)

# Products for conventional signal connection





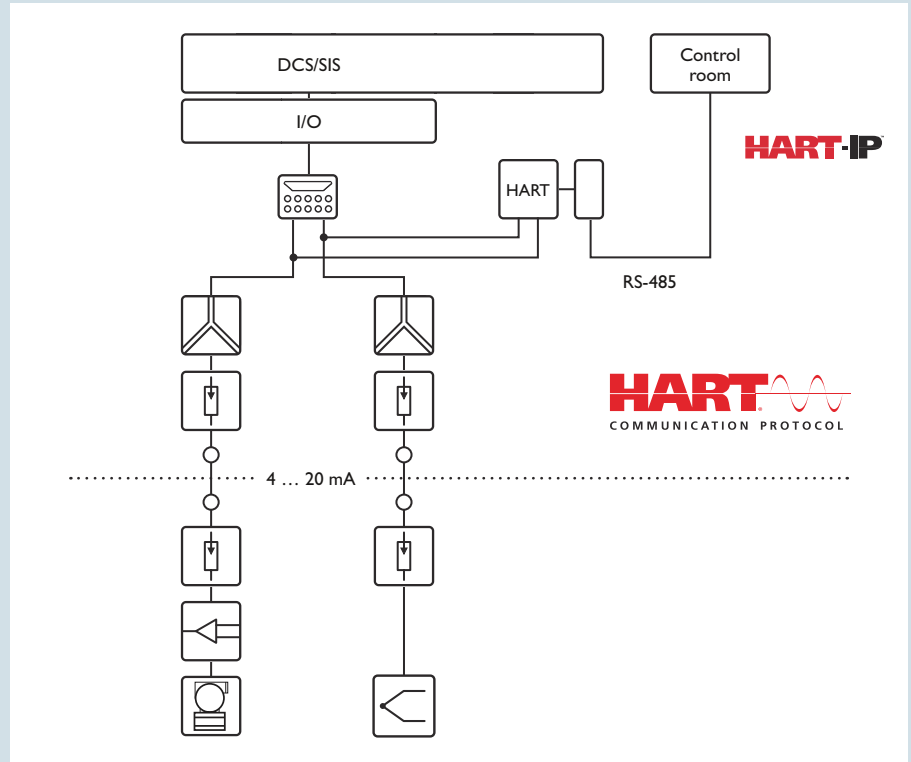

## Solutions for applications with HART communication

The bidirectional HART-compatible devices in the MACX series enable HART information to be integrated into separate engineering and management systems via the MACX MCR-S-MUX HART multiplexer and the corresponding wiring modules. Corresponding COM servers also support further processing via Ethernet. This also means that limit and diagnostic values, as well as information such as the calibration state or the status of intelligent field devices are integrated impact-free into process control systems and remote calibration can be performed.

All surge protection products are compatible with the HART protocol.



## HART communication

		 	 
		HART Multiplexer	COM server
Type	Order No.	MACX MCR-S-MUX <span style="color: #00A651;">2865599</span> MACX MCR-S-MUX-TB <span style="color: #00A651;">2308124</span>	GW DEVICE SERVER 1E/1DB9 <span style="color: #00A651;">2702758</span> GW DEVICE SERVER 1E/2DB9 <span style="color: #00A651;">2702760</span> GW DEVICE SERVER 2E/2DB9 <span style="color: #00A651;">2702761</span> GW DEVICE SERVER 2E/4DB9 FL <span style="color: #00A651;">2702763</span> COMSERVER BASIC 232/422/485 <span style="color: #00A651;">2313478</span>
		 Web code: <span style="color: #00A651;">#1567</span>	 Web code: <span style="color: #00A651;">#1584</span>
Description		16 or 32 channels per multiplexer	Transmission of up to 32 channels
		Connection of max. 4000 HART signals	Conversion of HART signals to Ethernet via COM server
Approvals		ATEX, UL	ATEX, UL





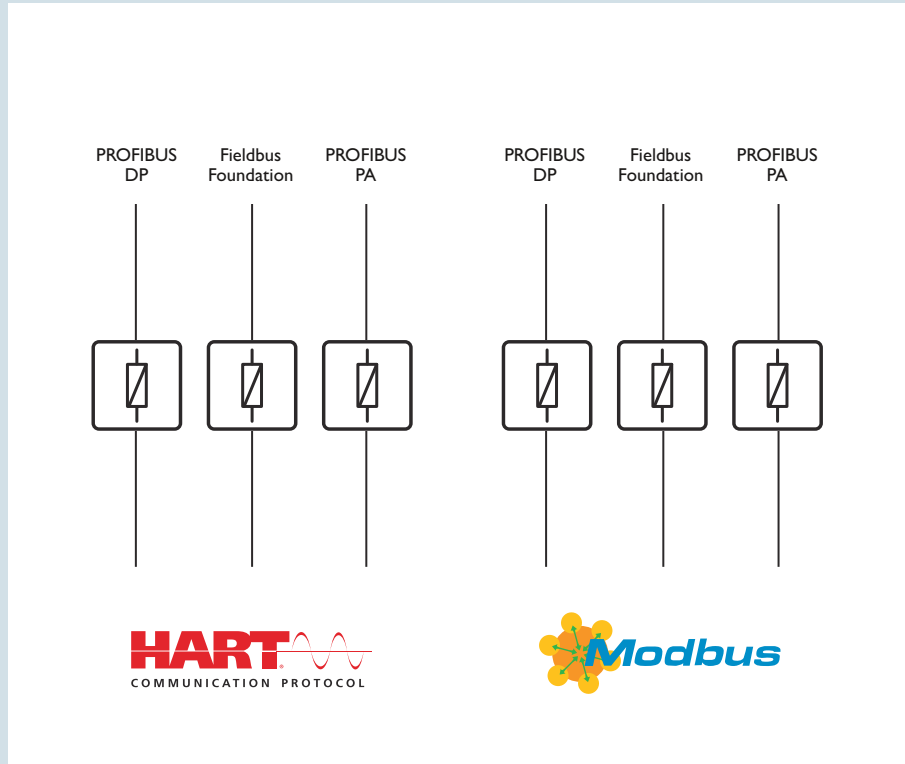

## Solutions with various protocols

A wide range of fieldbus systems can be easily integrated into your process system. The new gateways (GW PL FB...) enable the easy integration of a wide range of fieldbus systems and the networking of existing field instruments and data in your system. Existing Modbus or HART information is reliably converted to modern fieldbus systems, such as PROFIBUS DP, PROFIBUS PA or Fieldbus Foundation. You can therefore also easily connect your existing measuring devices that are installed in the field to new, future network infrastructures.

The PL FB protocol converters have four channels for connecting Modbus or HART devices to fieldbus systems such as PROFIBUS DP, PROFIBUS PA or Fieldbus Foundation devices.



## HART/Modbus protocol converter

		 	 
		<b>HART protocol converter</b>	<b>Modbus protocol converter</b>
Type	Order No.	GW PL FB/FF-HART GW PL FB/PA-HART GW PL FB/DP-HART	GW PL FB/FF-MODBUS GW PL FB/PA-MODBUS GW PL FB/DP-MODBUS
		<a href="#">2316360</a> <a href="#">2316361</a> <a href="#">2316362</a>	<a href="#">2316363</a> <a href="#">2316364</a> <a href="#">2316365</a>
		 Web code: <a href="#">#1793</a>	 Web code: <a href="#">#1699</a>
Description		Access to digital data from HART devices in the field	Access to digital data from Modbus devices in the field
		Extended runtime for special measuring instruments and otherwise inaccessible data	
		Reliable conversion from existing networks to faster communication paths	
Approvals		ATEX, IECEx, UL	ATEX, IECEx, UL

Detailed information and additional approvals can be found at: [phoenixcontact.com/products](http://phoenixcontact.com/products)

# Products for conventional signal connection

## Monitor energy flow and communicate energy data

Use network-capable EMpro measuring devices to monitor characteristic electrical data centrally and on site. Plug-in communication modules allow you to flexibly integrate the EMpro measuring devices into network structures and fieldbus systems. This means that measured values can even be made available in the control center for further processing.

### Your advantages:

- Direct access to measured values – directly on the device or remotely from the host computer
- User-friendly configuration – on site by following the operator guidance or via the integrated web server
- Easy integration into network structures, thanks to flexible connection options
- High degree of planning reliability and investment security, thanks to the option of expansion by adding function and communication modules

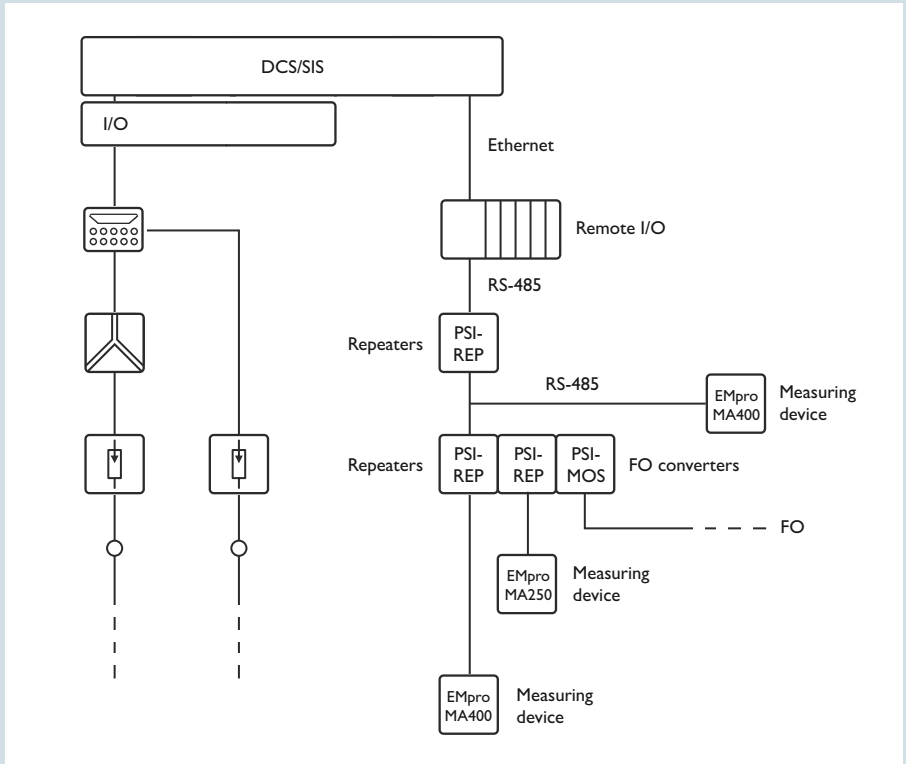

## Remote access to multiple measuring devices with just one IP address

The web server that has been integrated into the Ethernet communication modules allows you to conveniently configure key parameters online. It also allows remote access to key electrical characteristics such as current, voltage, power, energy, and harmonics. In your monitoring network, the master consists of an EMpro MA600 measuring device combined with an Ethernet gateway. You can easily configure the connected energy measurement devices as slaves via the web server interface. You can therefore access all energy data with just one IP address.





## EMpro measuring devices

The DIN rail adapter enables EMpro MA600 and EMpro MA400 built-in devices to also be mounted on the DIN rail.

EEM-MKT-DRA  
Order No. [2902078](#)



Measuring		EMpro MA600		EMpro MA400		EMpro MA200/250	
Type	Order No.	EEM-MA600 EEM-MA600-24DC	<a href="#">2901366</a> <a href="#">2902352</a>	EEM-MA400	<a href="#">2901364</a>	EEM-MA200 EEM-MA250	<a href="#">2901362</a> <a href="#">2901363</a>
		Web code: <a href="#">#1267</a>		Web code: <a href="#">#1267</a>		Web code: <a href="#">#1267</a>	
Voltage measurement		Directly up to 700 V or voltage transducer		Directly up to 519 V		Directly up to 519 V	
Current measurement		Current transformers		Current transformers		Current transformers	
Frequency		●		●		●	
Real power, reactive power, apparent power (+/-)		●		●		●	
Power factor		●		●		●	
Maximum mean values		●		●		●	
Mean values		●		–		–	
Trend performances		●		–		–	
Real energy meter (kWh)		kWh+ / kWh-		kWh+		kWh+	
Reactive energy meter (kvarh)		kvarh+ / kvarh-		kvarh+		kvarh+	
Apparent energy meter (kVAh)		kVAh		–		–	
Operating hours counter		●		●		●	
Accuracy class (EN 62053-22)		0.5 S		0.5 S		0.5 S	
Harmonic content		Up to 63rd		Up to 51st		Up to 51st	
Spectral analysis		Up to 63rd		–		–	
Approvals		UL		UL		UL	
<b>Function modules (optional)</b>							
1 pulse or alarm output		–		EEM-IMP-MA400	<a href="#">2904314</a>	Integrated	
2 pulse outputs		EEM-IMP-MA600	<a href="#">2904313</a>	–		–	
2 digital inputs, 2 digital outputs		EEM-2DIO-MA600	<a href="#">2901371</a>	–		–	
2 analog outputs		EEM-2AO-MA600	<a href="#">2901475</a>	–		–	
Storage		EEM-MEMO-MA600	<a href="#">2901370</a>	–		–	
<b>Communication modules (optional)</b>							
RS-485 (Modbus RTU)		EEM-RS485-MA600	<a href="#">2901367</a>	EEM-RS485-MA400	<a href="#">2901365</a>	Integrated (MA250 only)	
D-Sub (PROFIBUS)		EEM-PB12-MA600	<a href="#">2901418</a>	–		–	
Ethernet gateway with web server (Modbus TCP/RTU)		EEM-ETH-RS485-MA600	<a href="#">2901374</a>	–		–	
Ethernet with web server (Modbus/TCP)		EEM-ETH-MA600	<a href="#">2901373</a>	–		–	

Detailed information and additional approvals can be found at: [phoenixcontact.com/products](http://phoenixcontact.com/products)

# Products for conventional signal connection

## Solutions for intelligent motor control and monitoring

Three-phase pumps, agitators or actuators are monitored and controlled via a central controller. Communication is established either via gateways (e.g., PROFIBUS gateway) or a small-scale controller which transmits the sensor data (here EMM) using an I/O module. The switching device (ELR) is controlled via the EMM.

Motors up to 4 kW can be started using ELR hybrid motor starters.

For higher power ratings and current strengths, only ELR series solid-state contactors should be used.

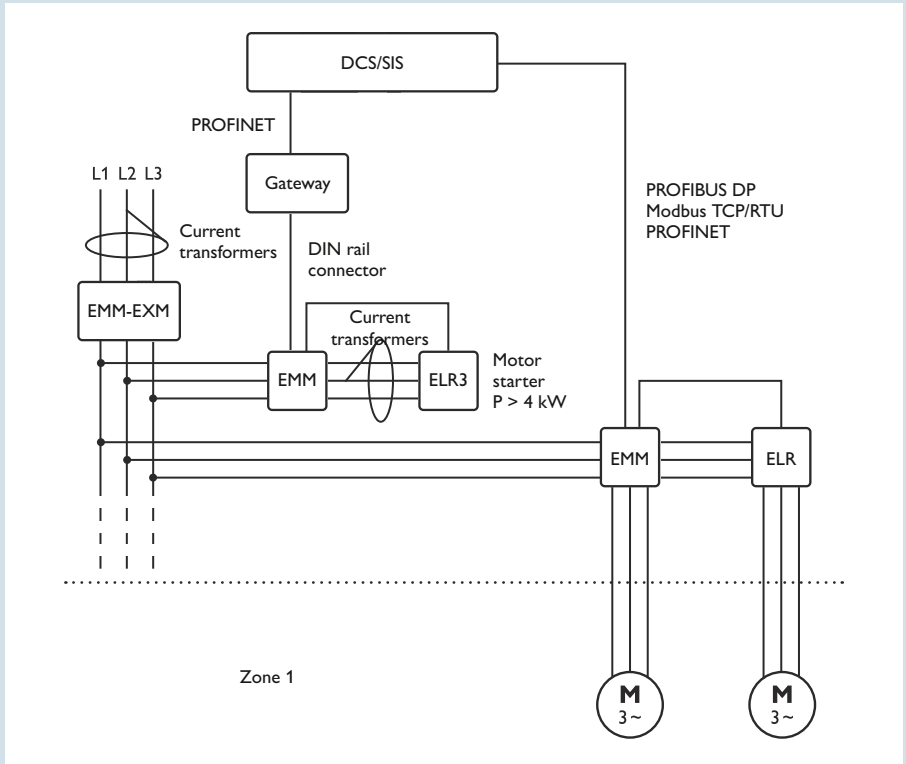

## Safe and available

### Emergency stop

An integrated safety function enables use in safety-relevant emergency stop applications.

### Forward running

Easy control directly via 24 V PLC output cards or 230 V AC signal.

### Reverse running

Optional: reversing function including locking circuit and load wiring







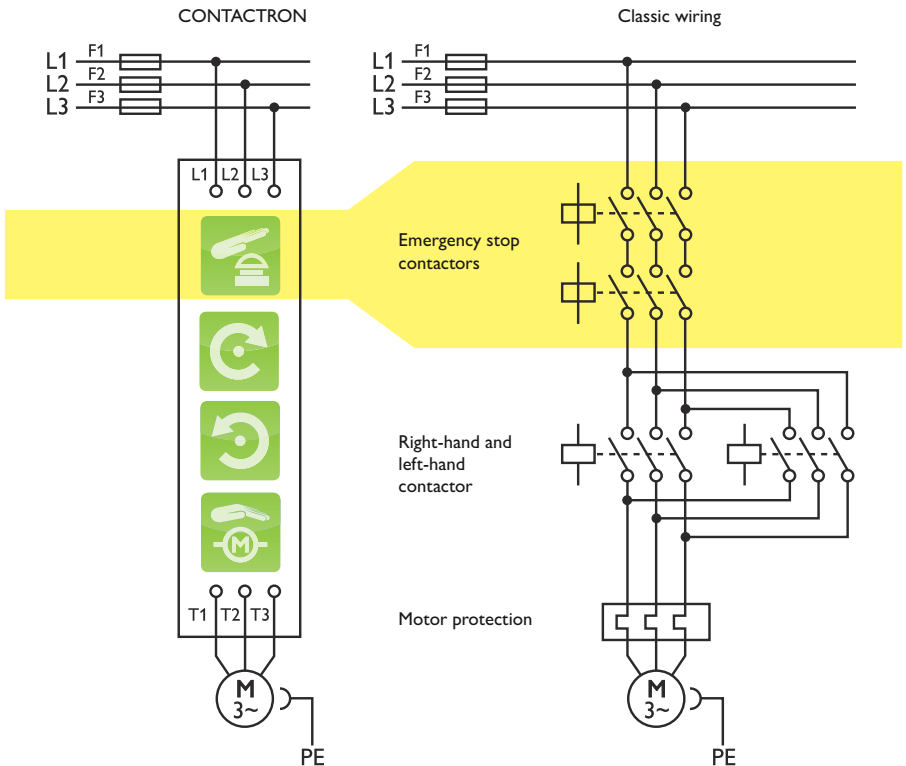

### Motor protection

Convenient protection, thanks to the electronic motor protection relay with automatic and remote reset function.

Web code: #1077



## Motor control and monitoring

				
	Electronic motor and machine management	Hybrid motor starters	Solid-state contactors	Electronic reversing load relay for DC motors
Type Order No.	EMM 3-24DC/... ...500AC-16-IFS <a href="#">2297523</a> ...500AC-IFS <a href="#">2297497</a> ...500AC-160-EXM-IFS <a href="#">2908603</a> ...500AC-90-EXM-IFS <a href="#">2908602</a>	ELR H5-... ...IES-SC-24DC/500AC-2 <a href="#">2900414</a> ...IES-SC-24DC/500AC-9 <a href="#">2900421</a> ...SC-24DC/500AC-9 <a href="#">2900538</a>  ELR H3-... ...IES-SC-24DC/500AC-2 <a href="#">2900567</a> ...IES-SC-24DC/500AC-9 <a href="#">2900569</a> ...SC-24DC/500AC-9 <a href="#">2900530</a>	ELR 2+1-24DC/500AC-37 <a href="#">2297277</a> ELR W2+1-24DC/500AC-37 <a href="#">2297374</a>	ELR W1/ 6-24DC/RDT <a href="#">2982757</a> ELR W1/10-24DC <a href="#">2964306</a>
	 <a href="#">#1262, #1921</a>	 Web code: <a href="#">#0568</a>	 Web code: <a href="#">#2026</a>	 Web code: <a href="#">#2037</a>
Approvals	ATEX, UL	ATEX, SIL, UL	UL	UL
Input voltage range	19.2 V DC ... 30 V DC	19.2 V DC ... 30 V DC	19.2 V DC ... 30 V DC	19.2 V DC ... 30 V DC
Output voltage range	42 V AC ... 575 V AC	48 V AC ... 550 V AC	48 V AC ... 550 V AC	–
Maximum load current	< 16 A / > 16 A with external current transformer	2.4 A/9 A	16 A / 37 A	Max. 10 A
Ambient temperature	-25°C ... +70°C	-25°C ... +70°C	-25°C ... +70°C	-20°C ... +60°C

Detailed information and additional approvals can be found at: [phoenixcontact.com/products](http://phoenixcontact.com/products)

## Clever switching and reliable protection

Switching and monitoring motor-driven pumps, agitators or actuators. Using electronic motor management with real power monitoring, dry running or a clogged filter can be detected and reported by choosing suitable switching thresholds. An emergency shutdown can be performed if necessary.

The availability and service life of the system is increased.

The use of external current transformers ensures measuring technology performance is not restricted. The system is integrated into a BUS system via gateways or ILC small-scale controllers.



# System cabling for process control systems

Wiring I/O modules with single wires is an extremely time-consuming process. Wiring errors and tedious troubleshooting cannot be ruled out. Interface cabling reduces assembly costs by using plug-in components to carry out wiring quickly, clearly, and without errors.

With VARIOFACE system cabling, it is possible to connect numerous I/O modules from renowned DCS and safety system manufacturers.



## ABB

The ABB S800 I/O system offers the option of carrying out wiring via D-SUB connections.



## Emerson

The Emerson DeltaV system can be used to install process wiring using mass termination blocks (MTB) with flat-ribbon cable plugs.

## Your advantages

- ✓ Error-free, uniform I/O wiring
- ✓ Solutions for DCS and safety system manufacturers ABB, Emerson, Honeywell, Siemens, Yokogawa and others
- ✓ System configuration of up to three components depending on the control system (front adapter, system cable, termination board)



### Honeywell

Front adapter solutions that are specially adapted to the Honeywell C series make field connection possible in next to no time.



### Siemens

The new front adapters for the S7-1500/ET 200MP let you use all features of the I/O modules and install your wiring safely, quickly, and without errors.



### Yokogawa

Special cables with molded connectors take on the front adapter function and cable routing during connection. This means that CENTUM® VP, CENTUM® CS 3000 R3 and ProSafe RS can be connected directly using cable routes.

# System cabling solutions

## Digital input signals with PLC relay



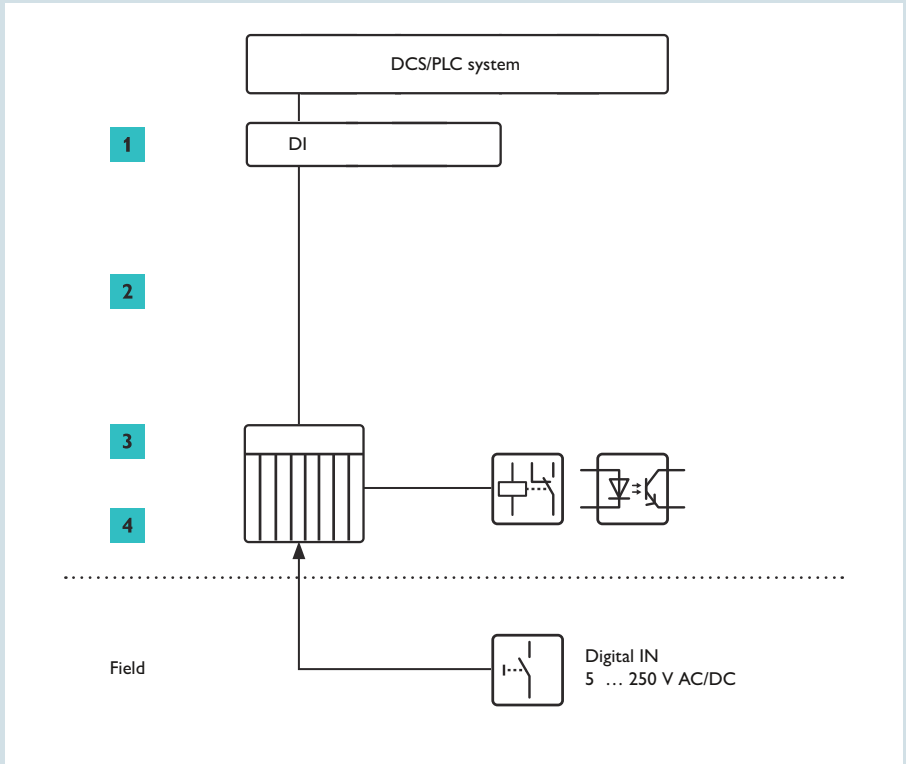

For many digital input signals, electrical isolation is necessary between the controller and the field. In many applications, signals also have to be adjusted. For these applications, Phoenix Contact offers special relays or solid-state relays. A V8 adapter offers the option to connect the switching elements with the respective input module error-free in next to no time using a cable and/or controller-specific front adapter via Plug and Play.





## Can be freely combined

Products from the Phoenix Contact PLC-Interface range can be freely connected with each other. Whether an electromechanical relay with a gold contact, optoelectronic switching elements for frequent switching cycles or a passive feed-through terminal block, your termination block is freely configurable and easy to assemble. Additional potential rails, various connection technologies and simple bridgeability give you added benefits for your application. The switching elements are very easy to replace if there is damage.



32-channel digital input					
DCS/PLC system	ABB S800	Emerson DeltaV	Honeywell C300	Siemens S7-1500/ET 200MP	Yokogawa Centum VP
Digital input card	DI818 (TU819)	VE4001S2T2B5 SE4001S2T2B5	TDIL01 TDIL11	6ES7 521-1BL00-0AB0	ADV151
	 Web code: #1526	 Web code: #1526	 Web code: #1526	 Web code: #1526	 Web code: #1526
Adapter <b>1</b>	–	–	2 x 2901879	1 x 2907381	–
Cable <b>2</b>	2 x 2304652	2 x 2298438	4 x 2302081	4 x 2288930	1 x 2314655
V8 relay adapter <b>3</b>	4 x 2296553	4 x 2304115	4 x 2296087	4 x 2296553	4 x 2296553
Relay/SSR <b>4</b>	32 x 2966317 or 32 x 2966773	32 x 2966317 or 32 x 2966773	32 x 2966317 or 32 x 2966773	32 x 2966317 or 32 x 2966773	32 x 2966317 or 32 x 2966773

8/16-channel digital input					
DCS/PLC system	ABB S800	Emerson DeltaV	Honeywell C300	Siemens S7-1500/ET 200MP	Yokogawa Centum VP
Digital input card	DI810 (TU812)	VE4001S2T1B3 SE4001S2T1B3	–	6ES7 521-1BH00-0AB0	–
	 Web code: #1526	 Web code: #1526	–	 Web code: #1526	–
Adapter <b>1</b>	–	–	–	1 x 2907381	–
Cable <b>2</b>	1 x 2304652	1 x 2300562	–	2 x 2288930	–
V8 relay adapter <b>3</b>	2 x 2296553	1 x 2304115	–	2 x 2296553	–
Relay/SSR <b>4</b>	16 x 2966317 or 16 x 2966773	8 x 2966317 or 8 x 2966773	–	16 x 2966317 or 16 x 2966773	–

Detailed information and additional approvals can be found at: [phoenixcontact.com/products](http://phoenixcontact.com/products)

# System cabling solutions

## Digital output signals with PLC relay

For many digital output signals, electrical isolation is necessary between the controller and the field. In many applications, output signals also have to be adjusted or amplified. For these applications, Phoenix Contact offers special relays or solid-state relays. A V8 adapter offers the option to connect the switching elements with the respective output module error-free in next to no time using a cable and/or controller-specific front adapter via Plug and Play.

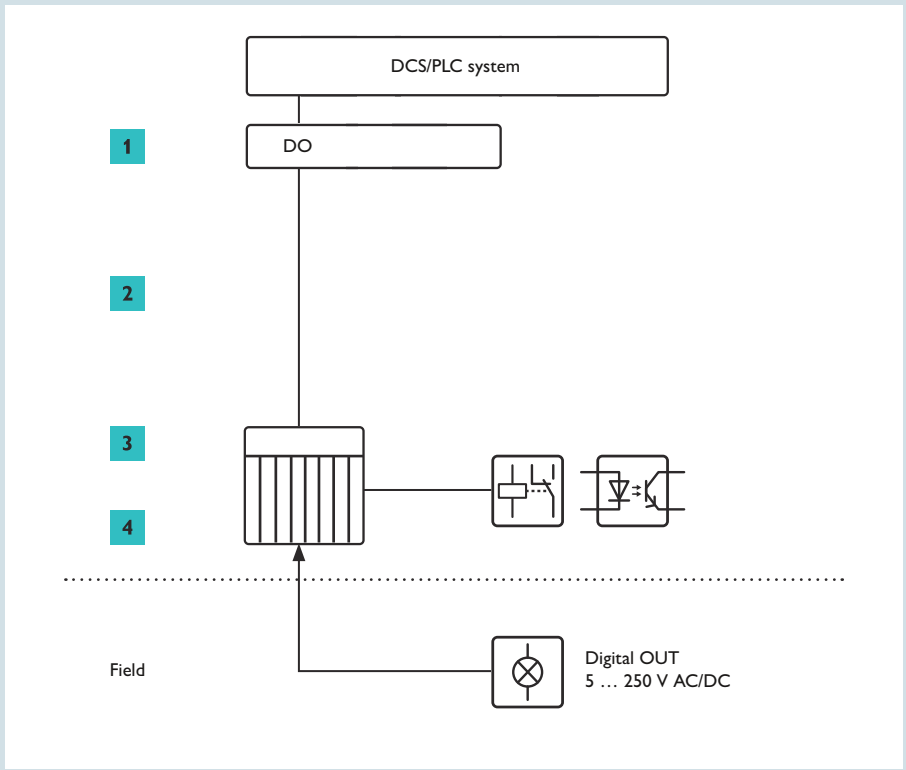





## Can be freely combined



The PLC-INTERFACE relay system is the interface between the controller and system I/O devices. The universal design is compact and saves a lot of space. At an overall width of 6.2 mm, power up to 250 V AC and 6 A can be switched. At a 14 mm overall width, switching is possible even up to 250 V AC and 10 A. Relay types with special input circuits or versions for high switch-on currents up to 130 A are also available. Products from the Phoenix Contact PLC-INTERFACE range can be freely combined with each other.

Whether as an electromechanical relay or optoelectronic switching element for frequent switching cycles, your termination block is freely configurable and easy to assemble. Additional potential rails, various connection technologies and simple bridgeability give you added benefits for your application. The switching elements are very easy to replace if there is damage.





32-channel digital output					
DCS/PLC system	ABB S800	Emerson DeltaV	Honeywell C300	Siemens S7-1500/ET 200MP	Yokogawa Centum VP
Digital output card	DO818 (TU819)	VE4002S1T2B6 SE4002S1T2B6	TDOB01 TDOB11	6ES7 522-1BL01-0AB0	ADV551
	 Web code: #1526	 Web code: #1526	 Web code: #1526	 Web code: #1526	 Web code: #1526
Adapter <b>1</b>	–	–	2 x 2900924	1 x 2907381	–
Cable <b>2</b>	2 x 2304652	2 x 2298438	4 x 2302081	4 x 2288930	1 x 2314655
V8 relay adapter <b>3</b>	4 x 2295554	4 x 2295554	4 x 2296061	4 x 2295554	4 x 2304102
Relay/SSR <b>4</b>	32 x 2966210 or 32 x 2966676	32 x 2966210 or 32 x 2966676	32 x 2966210 or 32 x 2966676	32 x 2966210 or 32 x 2966676	32 x 2966210 or 32 x 2966676

8/16-channel digital output					
DCS/PLC system	ABB S800	Emerson DeltaV	Honeywell C300	Siemens S7-1500/ET 200MP	Yokogawa Centum VP
Digital output card	DO810 (TU812)	VE4002S1T2B3 SE4002S1T2B3	–	6ES7 522-1BH00-0AB0	–
	 Web code: #1526	 Web code: #1526	–	 Web code: #1526	–
Adapter <b>1</b>	–	–	–	1 x 2907381	–
Cable <b>2</b>	1 x 2304652	1 x 2300588	–	2 x 2288930	–
V8 relay adapter <b>3</b>	2 x 2295554	1 x 2295554	–	2 x 2295554	–
Relay/SSR <b>4</b>	16 x 2966210 or 16 x 2966676	8 x 2966210 or 8 x 2966676	–	16 x 2966210 or 16 x 2966676	–

Detailed information and additional approvals can be found at: [phoenixcontact.com/products](http://phoenixcontact.com/products)

# System cabling solutions

## Analog input and output signals with MINI Analog / MINI Analog Pro

MINI Analog Pro is the latest generation of signal conditioners from Phoenix Contact. These signal conditioners offer you the simplest installation and start-up in a confined space, with space savings up to 65%.



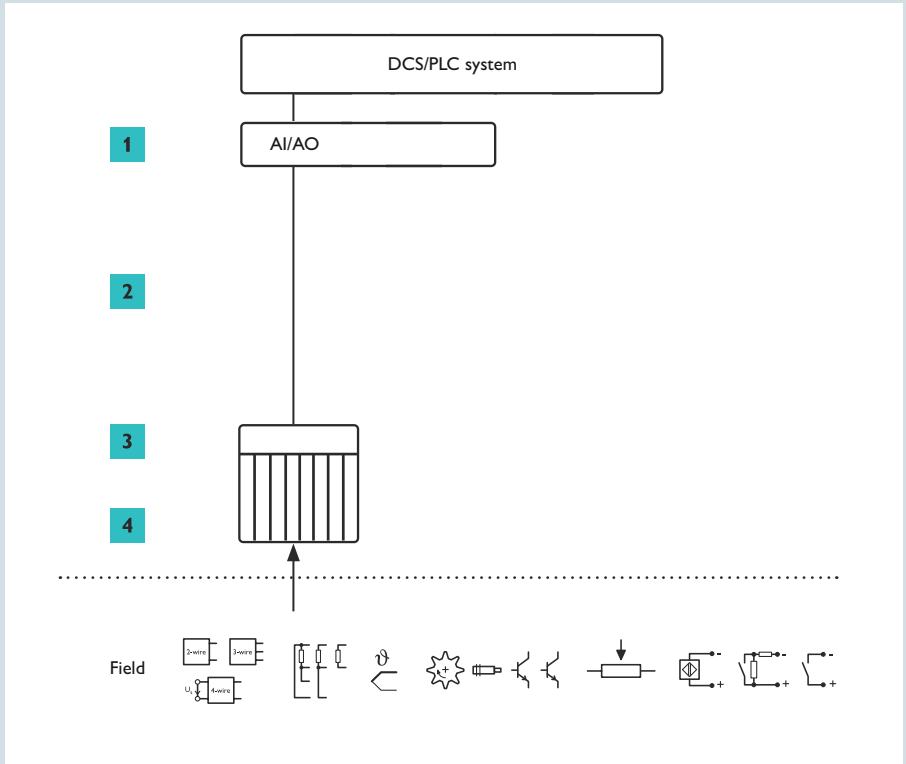

The extensive product range allows you to operate nearly all common analog standard applications up to Zone 2 applications.







## MINI Analog V8 adapter and Termination Carrier

The MINI Analog V8 adapter and the Termination Carrier form a compact solution for fast, error-free connection of signal conditioners. Signal connection is established by Plug and Play using standardized system cables. The highly compact signal conditioners for analog input and output are available for safe signal conditioning.



8/16-channel analog input					
DCS/SP system	ABB S800	Emerson DeltaV	Honeywell C300	Siemens S7-1500/ET 200MP	Yokogawa Centum VP
Analog input card	AI810 (TU810)	VE4003S2B6 SE4003S2B6	TAIX01 TAIX11	6ES7 531-7KF00-0AB0	AAI141 AAI143
	 Web code: #0492	 Web code: #0492	 Web code: #0492	 Web code: #0492	 Web code: #0492
Adapter <b>1</b>	–	–	1 x 2901423	–	–
Cable <b>2</b>	1 x 2318156	1 x 2926250	1 x 2305512	1 x 2318156	1 x 2314341
MINI Analog adapter/ Termination Carrier <b>3</b>	1 x 2901993	1 x 2906640	1 x 2906640	1 x 2901993	1 x 2905931
Signal conditioners <b>4</b>	8 x 2902014 or 8 x 2905628	16 x 2905628	16 x 2905628	8 x 2902014 or 8 x 2905628	16 x 2864079

8/16-channel analog output					
DCS/PLC system	ABB S800	Emerson DeltaV	Honeywell C300	Siemens S7-1500/ET 200MP	Yokogawa Centum VP
Analog output card	AO810 (TU810)	VE4005S2B1 SE4005S2B1	TAOX01 TAOX11	6ES7 532-5HF00-0AB0	AAI543
	 Web code: #0492	 Web code: #0492	 Web code: #0492	 Web code: #0492	 Web code: #0492
Adapter <b>1</b>	–	–	1 x 2901423	–	–
Cable <b>2</b>	1 x 2318156	1 x 2318156	1 x 2305512	2 x 2318156	1 x 2314341
MINI Analog adapter/ Termination Carrier <b>3</b>	1 x 2811268	1 x 2811268	1 x 2902934 or 1 x 2902933	2 x 2811268	1 x 2905905
Signal conditioners <b>4</b>	8 x 2905577	8 x 2905577	16 x 2905577	8 x 2905577	16 x 2905577

Detailed information and additional approvals can be found at: [phoenixcontact.com/products](http://phoenixcontact.com/products)

# System cabling solutions

## Analog input and output signals with MACX Analog

In all phases of the product lifecycle, MACX signal conditioners have been developed and produced in accordance with IEC 61508 standards for functional safety.

This ensures the highest level of safety for your machines and systems. Save planning and operating costs, thanks to the combination of high signal flexibility and comprehensive SIL certification.

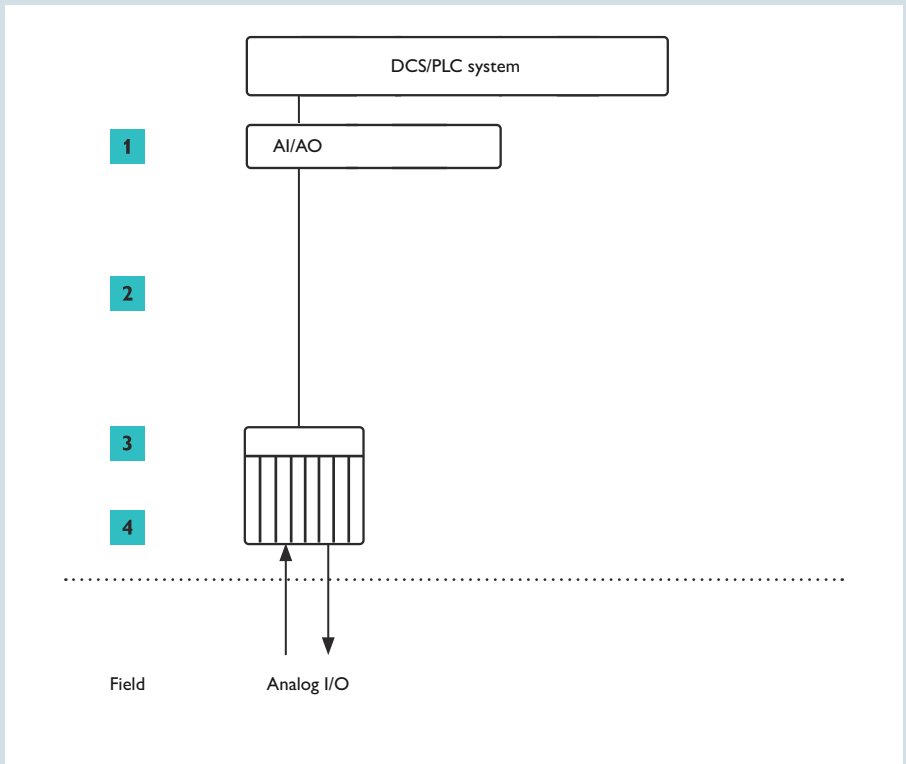











## Termination Carrier

The Termination Carrier is a compact solution for fast and error-free connection of MACX signal conditioners. Signal connection to the I/O card is established by Plug and Play using standardized system cables.

For safe signal conditioning, various signal conditioners are available for all types of analog input and output signals.



6/8/16-channel analog input					
DCS/PLC system	ABB S800	Emerson DeltaV	Honeywell C300	Siemens S7-1500/ET 200MP	Yokogawa Centum VP
Analog input card	AI845 (TU854)	VE4003S2B6 SE4003S2B6	TAIX01 TAIX11	6ES7336-4GE00-0AB0	AAI141 AAI143
	 Web code: #1142	 Web code: #1142	 Web code: #1142	 Web code: #1142	 Web code: #1142
Adapter <b>1</b>	–	–	1 x 2901423	1 x 2909508	–
Cable <b>2</b>	1 x 2302159	1 x 2926250	1 x 2305512	–	1 x 2314341
Termination Carrier <b>3</b>	1 x 1061347	1 x 2902932 or 1 x 2924854	1 x 2902932 or 1 x 2924854	1 x 2907411	1 x 2905677
Signal conditioners <b>4</b>	8 x 2865340 or 8 x 2865955	16 x 2865340 or 16 x 2865955	16 x 2865340 or 16 x 2865955	6 x 2865366 or 6 x 2924825	16 x 2865340 or 16 x 2865955

8/16-channel analog output					
DCS/PLC system	ABB S800	Emerson DeltaV	Honeywell C300	Siemens S7-1500/ET 200MP	Yokogawa Centum VP
Analog output card	AO854 (TU852)	2 x VE4005S2B1 2 x SE4005S2B1	TAOX01 TAOX11	2 x 6ES7 532-5HF00-0AB0	AAI534
	 Web code: #1142	 Web code: #1142	 Web code: #1142	 Web code: #1142	 Web code: #1142
Adapter <b>1</b>	–	–	1 x 2900622	–	–
Cable <b>2</b>	1 x 2302159	1 x 2926250	1 x 2305512	1 x 2926250	1 x 2314341
Termination Carrier <b>3</b>	1 x 1061346	1 x 2902932 or 1 x 2924854	1 x 2902932 or 1 x 2924854	1 x 2902932 or 1 x 2924854	1 x 2905201
Signal conditioners <b>4</b>	8 x 2865405 or 8 x 2865971	16 x 2865405 or 16 x 2865971	16 x 2865405 or 16 x 2865971	16 x 2865405 or 16 x 2865971	16 x 2865405 or 16 x 2865971

Detailed information and additional approvals can be found at: [phoenixcontact.com/products](http://phoenixcontact.com/products)

# System cabling solutions

## Digital output signals with PSRmini safety relays



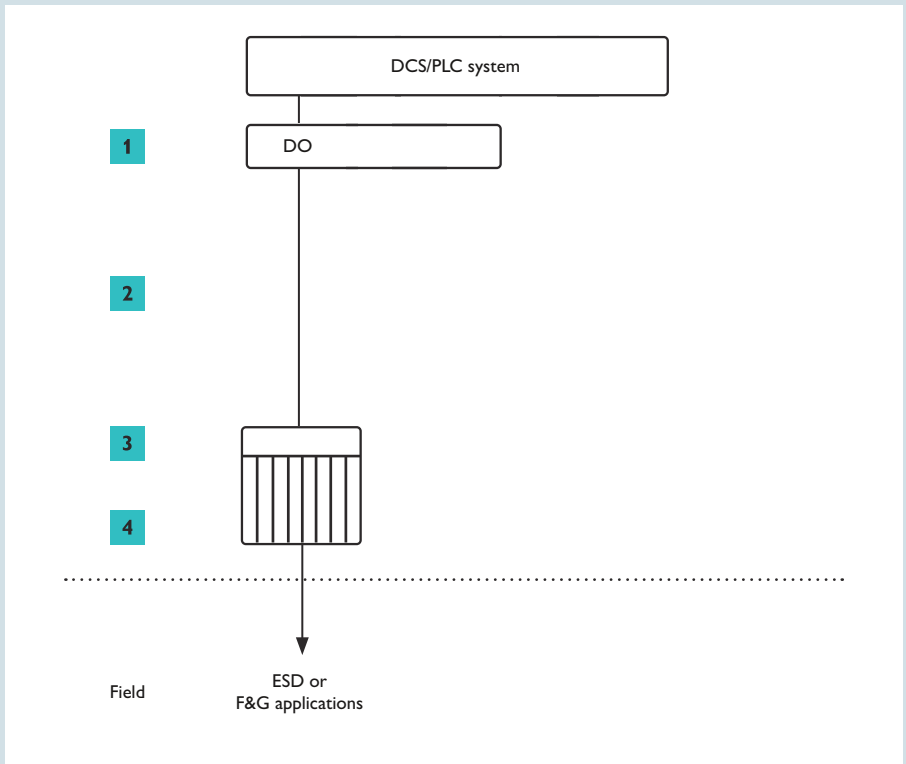

The PSRmini is the slimmest safety relay in the world with the performance of a large safety relay. At just 6 mm, these relays offer proven safety, thanks to force-guided contacts and space savings of up to 70%. The high-performance contacts let you switch loads up to 6 A safely. Force-guided contacts ensure maximum safety.







## Termination Carrier

The Termination Carrier is a compact solution for fast and error-free connection of the PSRmini safety relays. Signal connection to the controller is established by Plug and Play using standardized system cables. Adapted to the relevant distributed control systems and special requirements of your industry, you receive SIL-certified coupling modules for emergency shutdown and fire and gas applications.



Digital output emergency shutdown					
DCS/PLC system	ABB S800	Emerson DeltaV	Honeywell Universal Safe I/O	Siemens S7-1500/ET 200MP	Yokogawa ProSafe-RS
Digital output card	DO880 (TU810)	SIS CSLC (Charm)	FC-Rusio 3224	–	SDV541/SDV531
	 Web code: #1548	 Web code: #1548	 Web code: #1548	–	 Web code: #1548
Adapter <b>1</b>	–	–	2 x 2901423	–	–
Cable <b>2</b>	1 x 2926250	1 x 2926250	2 x 2305512	–	1 x 2314299
Termination Carrier <b>3</b>	1 x 2906609	1 x 2906609	2 x 2906609	–	1 x 2904113
PSR/PSRmini relays <b>4</b>	16 x 2702524	16 x 2702524	32 x 2702524	–	16 x 2986960

Digital output fire and gas					
DCS/PLC system	ABB S800	Emerson DeltaV SIS CSLC (Charm)	Honeywell Universal Safe I/O	Siemens S7-1500/ET 200MP	Yokogawa ProSafe-RS
Digital output card	DO880 (TU810)	SIS CSLC (Charm)	FC-Rusio 3224	–	SDV541/SDV531
	 Web code: #1548	 Web code: #1548	 Web code: #1548	–	 Web code: #1548
Adapter <b>1</b>	–	–	2 x 2901423	–	–
Cable <b>2</b>	1 x 2302159	1 x 2302159	2 x 2305512	–	1 x 2314341
Termination Carrier <b>3</b>	1 x 2902914	1 x 2902914	2 x 2902914	–	1 x 2904112
PSR-PC50 relay <b>4</b>	16 x 2904664	16 x 2904664	32 x 2904664	–	16 x 2904664

Detailed information and additional approvals can be found at: [phoenixcontact.com/products](http://phoenixcontact.com/products)

# System cabling solutions

## Passive signal transmission for digital or analog signals

Using the system cabling, you can connect your application using 1-, 2- or 3-conductor connection technology in next to no time. Special front adapters and system cables provide the corresponding signal marshaling. If a high-position connector such as D-SUB or FLK/IDC is already located on your automation components, a connection via universal modules or cables with a 1:1 connection can be established.

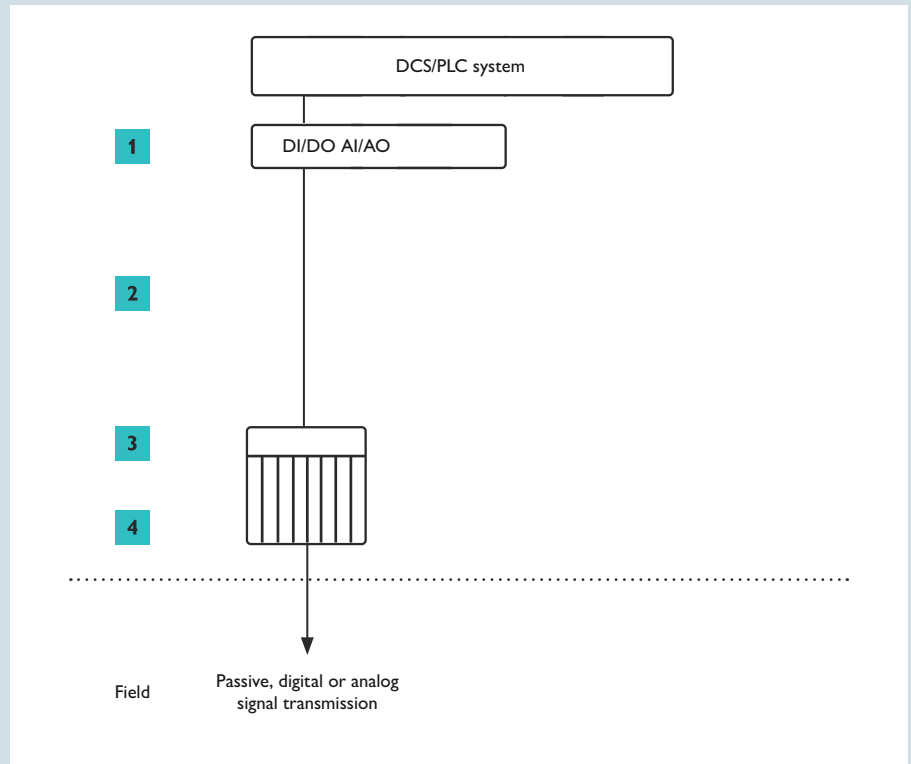











## VARIOFACE – Variable termination boards

Using the passive termination boards, you can connect the signals of your I/O modules directly with the field. Additional functions such as fuses or knife disconnection for each channel, as well as LED displays in combination with various connection technologies, offer broad variability for your application. Using the Plug and Play concept, you can wire your application without errors in next to no time, saving time and money.





32-channel digital input/output					
DCS/PLC system	ABB S800	Emerson DeltaV	Honeywell C300	Siemens S7-1500/ET 200MP	Yokogawa Centum VP
Digital input card	DI818 (TU819)	VE4001S2T2B5 SE4001S2T2B5	TDIL01 TDIL11	6ES7 521-1BL00-0AB0	ADV151
Digital output card	DO818 (TU819)	VE4002S1T2B6 SE4002S1T2B6	TDOB01 TDOB11	6ES7 522-1BL01-0AB0	ADV551
	 Web code: #1526	 Web code: #1526	 Web code: #1526	 Web code: #1526	 Web code: #1526
Adapter <b>1</b>	–	–	2 x 2901423	1 x 2907383	–
Cable <b>2</b>	2 x 2302159	1 x 2304908	2 x 2305512	1 x 2289094	1 x 2314299
Termination board <b>3</b>	2 x 2315188	1 x 2304689	2 x 2900675	1 x 2284523	1 x 2314451

8/16-channel analog input/output					
DCS/PLC system	ABB S800	Emerson DeltaV	Honeywell C300	Siemens S7-1500/ET 200MP	Yokogawa Centum VP
Analog input card	AI810 (TU812)	VE4003S2B4 SE4003S2B4	TAIX01 TAIX11	6ES7 531-7KF00-0AB0 6ES7 531-7NF00-0AB0	AAI141 AAI143
Analog output card	AO810 (TU812)	VE4005S2B3 SE4005S2B3	TAOX01 TAOX11	6ES7 532-5HF00-0AB0	AAI543
	 Web code: #1526	 Web code: #1526	 Web code: #1526	 Web code: #1526	 Web code: #1526
Adapter <b>1</b>	–	–	1 x 2900622	1 x 2907386	–
Cable <b>2</b>	1 x 2302159	1 x 2299327	1 x 2305512	1 x 2289094	1 x 2314341
Termination board <b>3</b>	1 x 2315188	1 x 2903599	2 x 2900675	1 x 2908495	1 x 2314642

Detailed information and additional approvals can be found at: [phoenixcontact.com/products](http://phoenixcontact.com/products)

# Fieldbus infrastructure: Genuine modularity in a fieldbus

The modular fieldbus components of the fieldbus product line enable communication from the process controller to the field devices for PROFIBUS-PA fieldbus applications. The device couplers in the pre-assembled field junction boxes connect the devices and ensure that segments are protected.

## Your advantages

- ✓ Increased availability of your processes with single-channel fieldbus barriers
- ✓ Time and money can be saved, thanks to needs-based installation, minimal planning effort, fast module exchange and flexible expansion



### PROFIBUS-PA muxer

Using PROFIBUS-PA-I/O muxers, signals from the field can be integrated directly into PROFIBUS PA.



### PROFIBUS DP/PA interface

The modular PROFIBUS interface enables transparent communication between PROFIBUS PA field devices and a higher-level PROFIBUS DP fieldbus. It can be extended to up to ten segments.



### Device coupler

Block and modular device couplers enable the infrastructure connection between the process fieldbus controller and the field devices.

PHOENIX CONTACT

# Fieldbus components

## Integrating I/Os directly in PROFIBUS PA

Analog and digital I/Os are integrated within a PROFIBUS PA system via a PA head station, Radioline I/O modules and a four-channel NAMUR digital input module. Since all signals are transferred to the control room from the field by way of PROFIBUS PA, you can perform the entire installation with standard PROFIBUS PA cables.

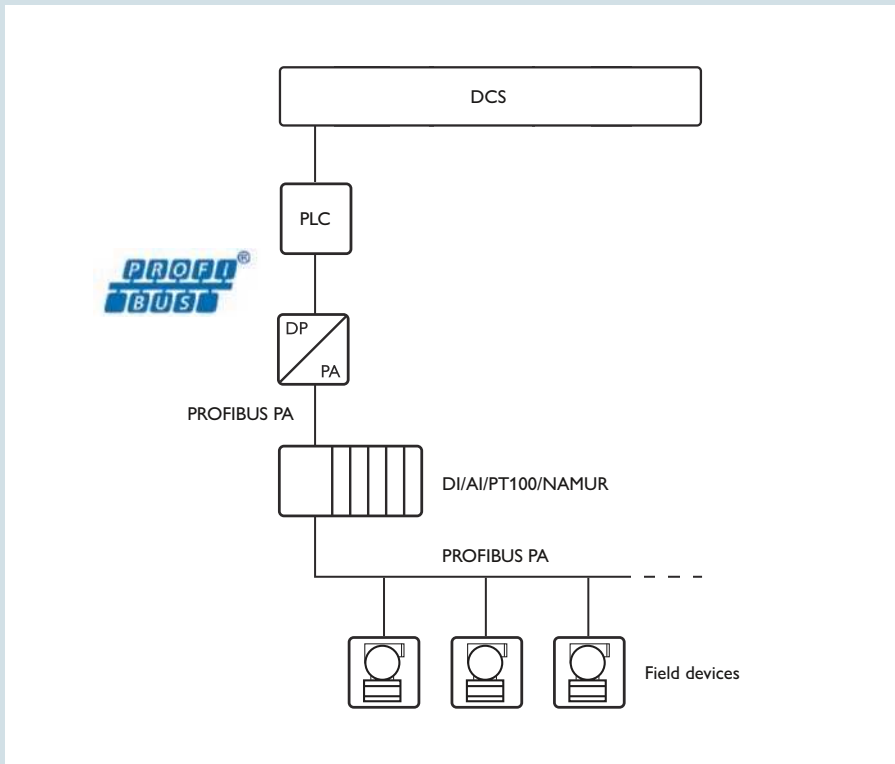

## PROFIBUS PA I/O gateway

All I/O modules of the well-known Radioline range are easily integrated into the PROFIBUS-PA system.

### Your advantages:







- No additional software is required, thanks to the preconfigured head station
- Connection of all I/Os in the field via PROFIBUS PA cables
- Integration into the host system via an EDD or GSD file
- Corrosion resistance in accordance with ANSI-ISA 71.04-1985 – 'Severity Level' G3
- Wide temperature range from -40°C to +70°C

**PROFIBUS PA head station**  
Variable with six different profiles



**Radioline extension modules**  
Can be integrated with a DIN rail connector

## PROFIBUS-PA-IO muxer

				
		<b>PROFIBUS PA head station</b>	<b>Radioline extension modules</b>	<b>NAMUR input model</b>
Type	Order No.	Valve controller: FB-MUX/HS/DIO-NAM/PA <a href="#">2316270</a>  Temperature and/or analog inputs: FB-MUX/HS/AIPA <a href="#">1005331</a>  Temperature and analog I/O: FB-MUX/HS/AIOTEMP/PA <a href="#">1005330</a>  Combination of digital and analog I/Os: FB-MUX/HS/DAIO/PA <a href="#">1005329</a>  24 high-density digital inputs: FB-MUX/HS/DI24/PA <a href="#">1005332</a>	Four digital inputs: RAD-DI4IFS <a href="#">2901535</a>  Eight digital inputs: RAD-DI8-IFS <a href="#">2901539</a>  Four digital outputs: RAD-DOR4-IFS <a href="#">2901536</a>  Eight digital outputs: RAD-DO8-IFS <a href="#">2902811</a>  Four analog inputs: RAD-AI4-IFS <a href="#">2901537</a>  Four Pt 100 inputs: RAD-PT100-4-IFS <a href="#">2904035</a>  Four analog outputs: RAD-AO4-IFS <a href="#">2901538</a>  Mixed module 2DI/2DO, 1AI/1AO: RAD-DAIO6-IFS <a href="#">2901533</a>	Four NAMUR digital inputs: FB-DI4/NM-IFS <a href="#">2316275</a>
		 Web code: <a href="#">#1792</a>	 Web code: <a href="#">#1927</a>	 Web code: <a href="#">#1792</a>
Description	<ul style="list-style-type: none"> <li>• Suitable for ATEX and IECEx Zone 2 installations</li> <li>• Meets the PA profile 3.02</li> <li>• Scalable and extendable as needed</li> </ul>			<ul style="list-style-type: none"> <li>• Connection to up to four NAMUR proximity switches</li> <li>• Meets standard EN 60947-5-6</li> <li>• Monitors the short circuit and open circuit of every sensor</li> <li>• Up to twelve NAMUR inputs (valve controllers)</li> <li>• Up to 24 NAMUR inputs (high-density DI)</li> </ul>
Approvals	ATEX, IECEx, G3, UL		ATEX, IECEx, G3, UL	ATEX, IECEx, G3, UL

Detailed information and additional approvals can be found at: [phoenixcontact.com/products](http://phoenixcontact.com/products)

### Product selection by inputs and outputs

Functions	NAMUR DI	Digital OUT	Digital IN	Analog IN	Analog OUT	Pt 100	I/Os total	Type	Order No.
Valve controller	12	8	–	–	–	–	20	FB-MUX/HS/DIO-NAM/PA	<a href="#">2316270</a>
Temperature and/or analog inputs	–	–	–	•	–	•	20	FB-MUX/HS/AI/PA	<a href="#">1005331</a>
Temperature and analog I/O	–	–	–	•	8	•	20	FB-MUX/HS/AIOTEMP/PA	<a href="#">1005330</a>
Combination of digital and analog I/Os	–	6	6	3	3	–	18	FB-MUX/HS/DAIO/PA	<a href="#">1005329</a>
24 high-density digital inputs	–	–	24	–	–	–	24	FB-MUX/HS/DI24/PA	<a href="#">1005332</a>
24 high-density NAMUR digital inputs	24	–	–	–	–	–	24	FB-MUX/HS/DI24/PA	<a href="#">1005332</a>

# Fieldbus components

## Solutions for the fieldbus

Phoenix Contact offers a complete solution for your fieldbus application. It consists of trunk line modules, device couplers, pre-assembled cables, appropriate surge protection, and ready-mounted field junction boxes that can be assembled according to your specific requirements.

All surge protection products listed in the "Conventional signal connection to process control systems" section (page 54 ff.) are suitable for effective surge protection.

- Connection of all I/Os in the field via PROFIBUS PA cables

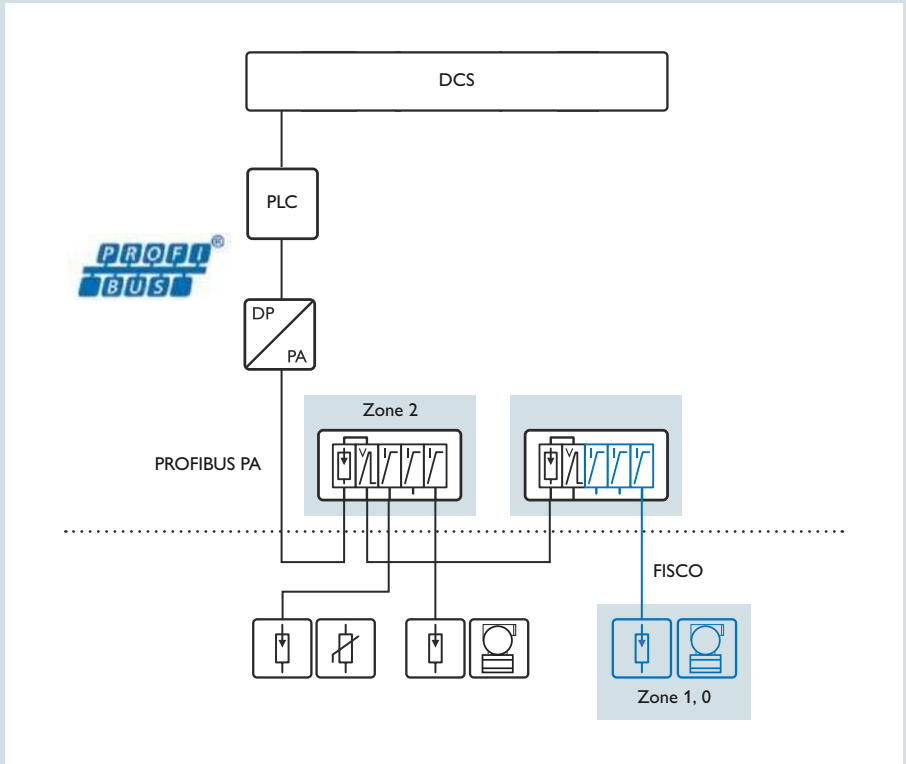











## PROFIBUS PA for process automation

We offer a tried-and-tested solution for process automation. It requires little space and offers many options for increasing reliability even further, giving you a decisive advantage when it comes to state-of-the-art process automation projects.

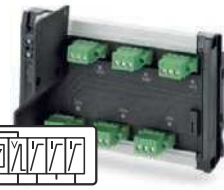
The fieldbus couplers with block and modular designs enable you to meet all customer requirements. In order to network control systems with the field devices, we offer complete fieldbus system architecture solutions along with DP/PA couplers, surge protection, cables and lines.

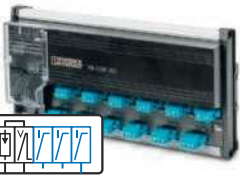

## PROFIBUS DP/PA coupler

		 	 	 	 
		<b>PROFIBUS DP/PA interface</b>	<b>Modular device couplers</b>	<b>Zone 2 block device coupler</b>	<b>Zone 1 block device coupler</b>
Type	Order No.	DP/PA gateway: FB-HSB-DP/PA <b>2316370</b>  DP repeater: FB-DP-RPTR <b>2316373</b>  DP repeater and scope: FB-DP-RPTR/SC <b>2316374</b>  PA scope: FB-PA/SC <b>2316375</b>  6 A power supply: FB-HSP-PLUG/24DC/6A <b>2316383</b>	One trunk line: FB-ET <b>2316048</b> FB-ET/E <b>2316050</b>  Two branch lines: FB-2SP <b>2316051</b> FB-2SP/E <b>2316052</b>  One FISCO connection: FB-2SP/24DC <b>2316352</b>	Six branch lines: FB-6SP <b>2316307</b>  Twelve branch lines: FB-12SP <b>2316310</b>	Eight branch lines: FB-8SP ISO <b>2316311</b>  Twelve branch lines: FB-12SP ISO <b>2316312</b>
		 Web code: <b>#1885</b>	 Web code: <b>#1494</b>	 Web code: <b>#1494</b>	 Web code: <b>#1494</b>
Approvals		UL	ATEX, IECEx, UL	ATEX, IECEx, UL	ATEX, IECEx, UL

Detailed information and additional approvals can be found at: [phoenixcontact.com/products](http://phoenixcontact.com/products)

## PROFIBUS PA can also have a redundant configuration

The PROFIBUS-DP/PA coupler enables eight PROFIBUS-PA segments to be set up. The head station is structured modularly according to the requirements of your system. A redundant set up is also possible and increases system availability further. A high-performance 6 A power supply is available as an option.

The device couplers ensure the fast coupling of your field devices to the PROFIBUS-PA chain and are permitted up to and including Zone 1. The powerful embedded web server enables configuration and diagnostics in case of error.

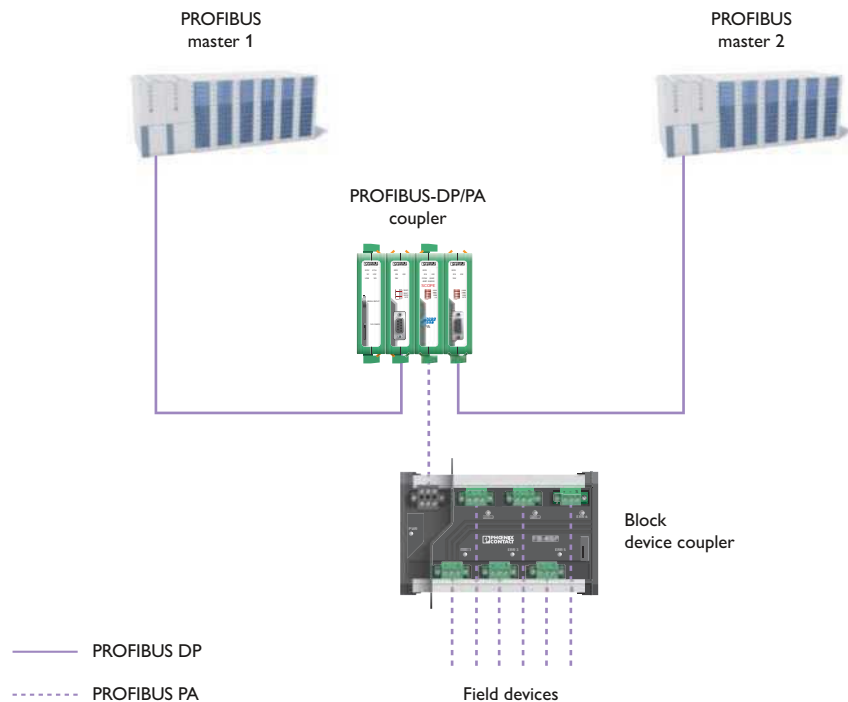

# Fieldbus components

## Solutions for the fieldbus power supply

A high-availability power supply is required for the safe and reliable operation of a FOUNDATION Fieldbus H1 segment. Phoenix Contact offers simple and redundant fieldbus power supplies for this purpose.

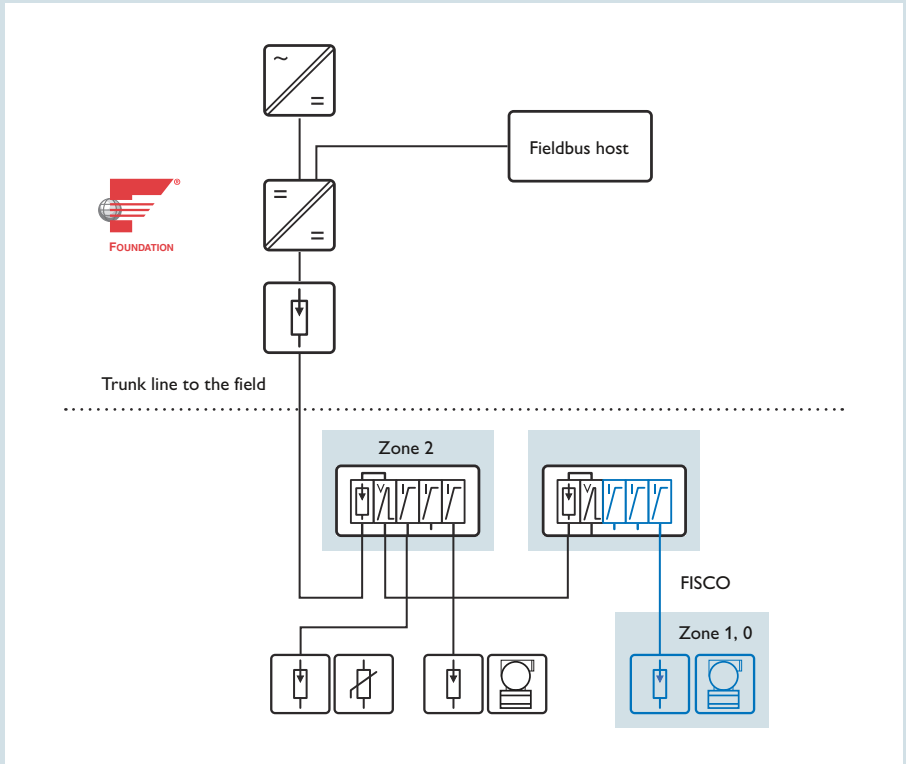













## Diagnostics for FOUNDATION Fieldbus in the field

The field diagnostics module is used to check the signal quality of the fieldbus directly in the field in environments that are potentially susceptible to interference. The diagnostics enable preventive measures to be taken to ensure optimum device availability and prevent the sudden loss of communication between the devices. Integration in the control level takes place via standard H1 communication and device management using DD (Device Description), EDDL (Electronic Device Description Language), and DTM (Device Type Manager). Due to use in the field, the measurements are not affected by long cable paths. The data is transmitted back to the control room in real time, where it can be evaluated directly by the system operator. This means that no maintenance authorizations or process interruptions are required.

















## Components for the fieldbus power supply

		 	 	 	 
		<b>Redundant fieldbus power supply</b>	<b>Power supply unit for redundant four-channel fieldbus power supply</b>	<b>Field diagnostics module for FOUNDATION Fieldbus</b>	<b>Surge protection</b>
Type	Order No.	FB-PS-BASE/EX <a href="#">2316145</a> FB-PS-PLUG-24DC/28DC/0.5/EX <a href="#">2316132</a>  D-FB-PS <a href="#">2316226</a>  ZEC 1,5/ 4-LPV-5,0 C2,4 BK <a href="#">1793260</a> ZEC 1,0/ 6-LPV-3,5 C1 <a href="#">1915699</a>  UC-TM 16 <a href="#">0819217</a> UC-TMF 16 <a href="#">0819262</a>	FB-PS-MB-... ...Y/EX <a href="#">2316148</a> ...I/EX <a href="#">2316149</a> ...25DSUB/EX <a href="#">2316146</a>  Accessories: FB-PS-PLUG-24DC/28DC/0.5/EX <a href="#">2316132</a>	FB-DIAG/FF/LI <a href="#">2316284</a> FB-DIAG/FF/NC <a href="#">2316297</a>	PT 2X2-FF-ST <a href="#">2800755</a> PT 4-BE <a href="#">2839402</a> PT 4+F-BE <a href="#">2839415</a>  S-PT-EX-24DC <a href="#">2800034</a> S-PT-EX-24DC-1/2" <a href="#">2800035</a>
		 Web code: <a href="#">#1885</a>	 Web code: <a href="#">#1494</a>	 Web code: <a href="#">#1494</a>	 Web code: <a href="#">#1494</a>
Approvals		ATEX, IECEx, UL	ATEX, IECEx, UL	ATEX, IECEx, UL	ATEX, IECEx, UL

## Device coupler, field connection boxes, and installation accessories

		 	 	 	 
		<b>Modular device coupler</b>	<b>Zone 2 block device coupler</b>	<b>Zone 1 block device coupler</b>	<b>Field connection boxes and installation accessories</b>
Type	Order No.	One trunk line: FB-ET <a href="#">2316048</a> FB-ET/E <a href="#">2316050</a>  Two branch lines: FB-2SP <a href="#">2316051</a> FB-2SP/E <a href="#">2316052</a>  One FISCO connection: FB-2SP/24DC <a href="#">2316352</a>	Six branch lines: FB-6SP <a href="#">2316307</a>  Twelve branch lines: FB-12SP <a href="#">2316310</a>	Eight branch lines: FB-8SP ISO <a href="#">2316311</a>  Twelve branch lines: FB-12SP ISO <a href="#">2316312</a>	FB1-S1-6SP-T-0-10-00-0-0 <a href="#">2316420</a> FB1-S1-6SP-S-0-10-00-0-0 <a href="#">2316446</a>  FB2-S1-12SP-S-0-16-00-0-0 <a href="#">2316433</a> FB2-S1-12SP-T-0-16-00-0-0 <a href="#">2316417</a>
		 Web code: <a href="#">#1494</a>	 Web code: <a href="#">#1494</a>	 Web code: <a href="#">#1494</a>	 Web code: <a href="#">#1494</a>
Approvals		ATEX, IECEx, UL	ATEX, IECEx, UL	ATEX, IECEx, UL	ATEX, IECEx, UL

Detailed information and additional approvals can be found at: [phoenixcontact.com/products](http://phoenixcontact.com/products)

# Remote control solutions for communication infrastructure

Phoenix Contact offers a comprehensive product range for interference-free data transmission in remote or wide-ranging networks and for worldwide system monitoring. Our high-performance interface devices support all leading bus systems as well as the various transmission media.

In addition to copper-based interface devices, solutions for wireless and fiber optic (FO) transmission are available.

## Your advantages

- ✓ Universal data links – worldwide and control-independent
- ✓ Secure communication – integrated security functions protect your applications and expertise
- ✓ Robust hardware – durable, high-performance, and reliable use in harsh industrial environments



## Copper-based data transmission

By electrically isolating segments of the network, you increase the availability and performance of your system.



### Optical data transmission

Fiber-optic data transmission via light waves is now the norm for implementation in highly critical applications with very high requirements for the system availability.



### Industrial telecommunications

For networking machines and systems over private and public networks, we offer you an extensive range of modem and protocol converters suited for your industry.



### Wireless

Depending on the distance and the signals to be transmitted, different wireless technologies such as Trusted Wireless, BT, and GSM are available.



# Remote control solutions and wireless technology

## Solutions for the serial connection of distributed I/O devices

Various serial systems, such as Modbus/RTU or PROFIBUS, are used for connecting remote I/O (RIO) devices. Various interface devices are required in order to create high-performance and interference-free networks. These devices adapt to different interfaces and provide electrical isolation, as well as increasing the range and speed in the network. Data can be transmitted via copper, fiber optics or wirelessly for a wide range of different requirements.

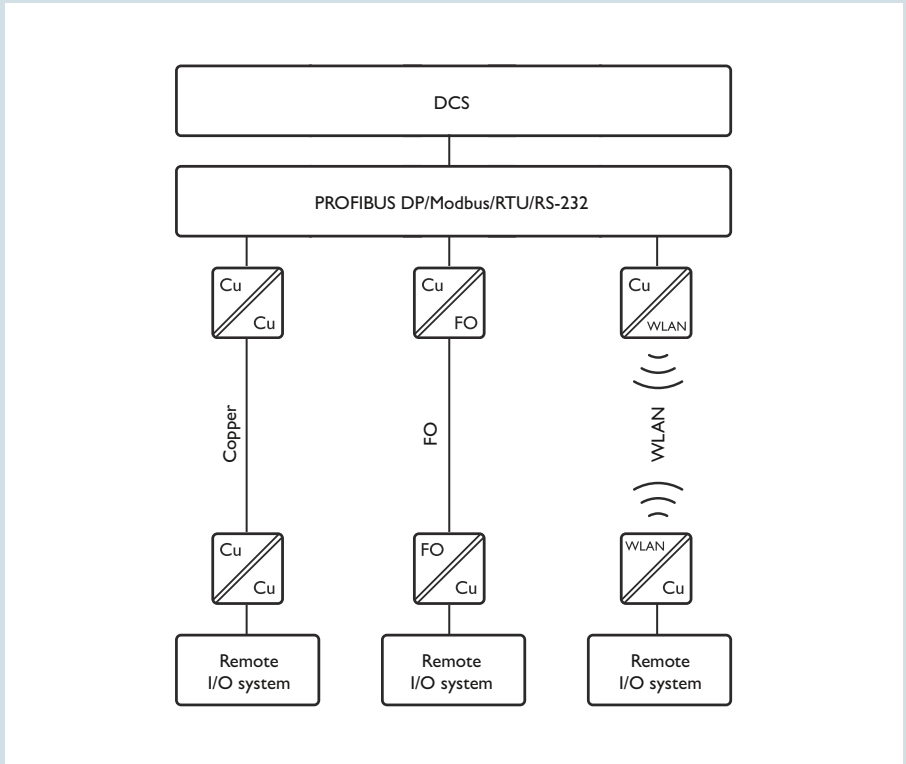













## Transmission ranges

- Copper – standard: maximum 1200 m (depending on cable type and data rate)
  - Copper – SHDSL: up to 20 km
  - FO converter
    - 660 nm:
      - 100 m (polymer fiber)
      - 800 m (HCS fiber)
    - 850 nm:
      - 2800 m (HCS fiber)
      - 3300 m (multimode fiberglass 62.5/125)
      - 4500 m (multimode fiberglass 50/125)
    - 1300 nm:
      - 22 km (multimode fiberglass 62.5/125)
      - 25 km (multimode fiberglass 50/125)
      - 45 km (single-mode fiberglass 9/125)
- Can vary depending on the bus system used.

- Wireless
  - Bluetooth: up to 150 m
  - Trusted Wireless 2.4 GHz:
    - up to 800 m with omnidirectional antenna
    - up to 4.5 km with directional antennas
  - Trusted Wireless 900 MHz: 32 km
  - Trusted Wireless 868 MHz: 20 km

- GSM mobile communication: worldwide



	Copper standard	Copper SHDSL extender	Fiber optics media converters	Wireless
	 	 	 	 
<b>PROFIBUS DP</b>				
Type Order No.	PSI-REP-PROFIBUS/12MB <sup>1</sup> 2708863 PSM-ME-RS485/RS485-P <sup>1</sup> 2744429 PSI-TERMINATOR-PB <sup>2</sup> 2313944 SUBCON-PLUS-PROFIB/SC2 2708232 SUBCON-PLUS-PROFIB/PG/SC2 2708245	PSI-MODEM-SHDSL/PB 2313656	PSI-MOS-PROFIB/FO 850 E 2708274 PSI-MOS-PROFIB/FO 850 T 2708261 PSI-MOS-PROFIB/FO1300 E 2708559 PSI-MOS-PROFIB/FO1300 T 2708892	RAD-2400-IFS <sup>1</sup> 2901541
<b>Modbus/RTU/ASCII</b>				
Type Order No.	PSI-REP-RS485W2 <sup>1</sup> 2313096 PSM-ME-RS485/RS485-P <sup>1</sup> 2744429 FL COMSERVER UNI 232/422/485 <sup>1</sup> 2313452 SUBCON-PLUS M1 2761826 SUBCON-PLUS F1 2744267	PSI-MODEM-SHDSL/SERIAL 2313669	PSI-MOS-RS485W2/FO 850 E 2708339 PSI-MOS-RS485W2/FO 850 T 2708326 PSI-MOS-RS485W2/FO1300 E 2708562 PSI-MOS-RS422/FO 660 E 2708342 PSI-MOS-RS422/FO 660 T 2708384 PSI-MOS-RS422/FO 850 E 2708355 PSI-MOS-RS422/FO 850 T 2708397 PSI-MOS-RS422/FO1300 E 2708575	RAD-2400-IFS <sup>1</sup> 2901541 RAD-900-IFS 2 <sup>2</sup> 2901540 RAD-868-IFS <sup>3</sup> 2904909
<b>RS-232</b>				
Type Order No.	PSM-ME-RS232/RS232-P <sup>1</sup> 2744461 PSM-ME-RS232/RS485-P <sup>1</sup> 2744416 PSM-EG-RS232/422-P/4K 2761266 FL COMSERVER BASIC 232/422/485 <sup>1</sup> 2313478 FL COMSERVER PRO 232/422/485 2313465 PSI-DATA/BASIC-MODEM/RS232 <sup>3</sup> 2313067	PSI-MODEM-SHDSL/SERIAL 2313669	PSI-MOS-RS232/FO 850 E 2708371 PSI-MOS-RS232/FO 850 T 2708423 PSI-MOS-RS232/FO1300 E 2708588	PSI-GPRS/GSM-MODEM/RS232-QB 2313106 RAD-2400-IFS <sup>1</sup> 2901541 FL COMSERVER WLAN 232/422/485 2313559 RAD-900-IFS 2 <sup>2</sup> 2901540
	 Web code: #1885	 Web code: #1885	 Web code: #1885	 Web code: #1927
<b>Approvals</b>				
	G3 <sup>1</sup> ATEX, G3, UL <sup>2</sup> ATEX, G3 <sup>3</sup> G3, UL	ATEX	ATEX, G3, UL	G3 <sup>1</sup> ATEX, IECEx, G3, UL <sup>2</sup> G3, UL <sup>3</sup> ATEX, G3

Detailed information and additional approvals can be found at: [phoenixcontact.com/products](http://phoenixcontact.com/products)

# Remote control solutions and wireless technology

## Solutions for creating distributed Ethernet networks

In addition to communication on the SCADA level, Ethernet is now increasingly being used to transmit video and I/O information for the field level. The physical limitations require alternative solutions for covering large distances. SHDSL technology allows simple two-wire lines to be used for data transmission up to 20 km. In contrast, fiber optic technology can cover distances of up to 40 km and is also completely immune to electromagnetic compatibility. At the same time, the fiber optic paths provide high-quality electrical isolation between the connected system parts.



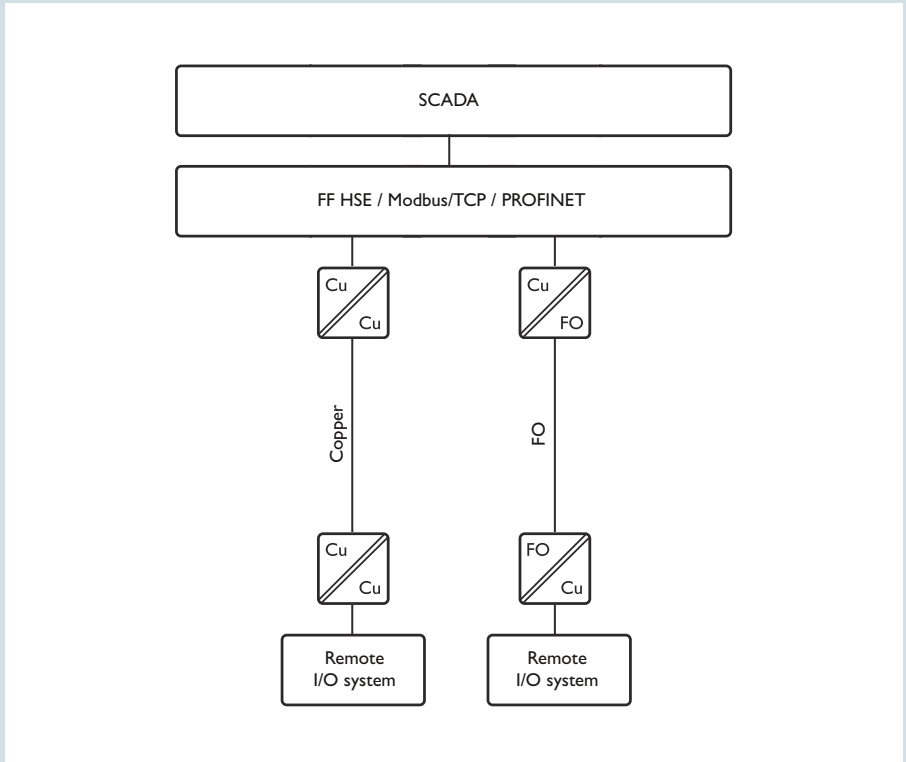









For retrofitting tasks concerning Modbus systems, the COM server can be implemented easily between Modbus/RTU/ASCII systems and Modbus/TCP controllers.



## Transmission ranges

- Copper – standard: 100 m
- Copper – SHDSL: up to 20 km
- FO converter:
  - 660 nm:
    - 50 m (polymer fiber 980/1000)
    - 100 m (HCS standard fiber 200/230)
    - 300 m (HCS-GI broadband fiber 200/230)
  - 1300 nm:
    - 2 km (HCS-GI broadband fiber 200/230)
    - 10 km (multimode fiberglass)
    - 36 km (single-mode fiberglass)



	Copper serial device server	Copper SHDSL extender	Fiber optics media converters	Ethernet patch panel
	 	 	 	 
<b>Modbus/TCP, PROFINET, FOUNDATION Fieldbus HSE</b>				
Type Order No.	GW DEVICE SERVER ... ...1E/1DB9 2702758 ...1E/2DB9 2702760 ...2E/2DB9 2702761 ...2E/4DB9 2702763  GW MODBUS TCP/RTU ... ...1E/1DB9 2702764 ...1E/2DB9 2702765 ...2E/2DB9 2702766 ...2E/4DB9 2702767  FL COMSERVER BASIC 232/422/485 2313478  FL COMSERVER UNI 232/422/485 2313452	TC EXTENDER ... ...6004 ETH-2S 2702255 ...4001 ETH-1S 2702253 ...2001 ETH-2S 2702409	FL MC EF ... ...1300 MM SC <sup>1</sup> 2902853 ...1300 SM SC <sup>1</sup> 2902856 ...1300 MM ST <sup>1</sup> 2902854 ...WDM-SET SC <sup>1</sup> 2902660  FL MC 2000E LC 2891056 FL MC 2000E SM40 LC 2891156  FL MC 2000T SC 2891315 FL MC 2000T ST 2891316 FL MC 2000T SM20 SC 2891317 FL MC 2000T SM40 SC 2891318  FL MC 1000 SC 2891320 FL MC 1000 ST 2891321	FL-PP-RJ45-SCC <sup>1</sup> 2901642 FL-PP-RJ45-SC <sup>1</sup> 2901643 FL-PP-RJ45-LSA 2901645 FL-PP-RJ45/RJ45 <sup>1</sup> 2901646 FL-PP-RJ45/RJ45-B 2904933  FL CAT5 TERMINAL BOX 2744610  PP-RJ-RJ 2703015 PP-RJ-SC 2703016 PP-RJ-SCC 2703018 PP-RJ-RJ-F 2703020 PP-RJ-SC-F 2703021 PP-RJ-SCC-F 2703022
	 Web code: #1584	 Web code: #0943	 Web code: #1578	 Web code: #1788, #1799
<b>Approvals</b>				
	ATEX, UL	ATEX	G3 <sup>1</sup> ATEX, G3, UL	G3 <sup>1</sup> ATEX, G3

Detailed information and additional approvals can be found at: [phoenixcontact.com/products](http://phoenixcontact.com/products)

# Remote control solutions and wireless technology

## Connecting the world with industrial telecommunications

Global networking of machines and systems. Alarm generation, remote maintenance, and continual data acquisition. From traditional two-wire transmission using an Ethernet extender or ADSL modem/router up to broadband mobile routers. We offer the right system for every application.

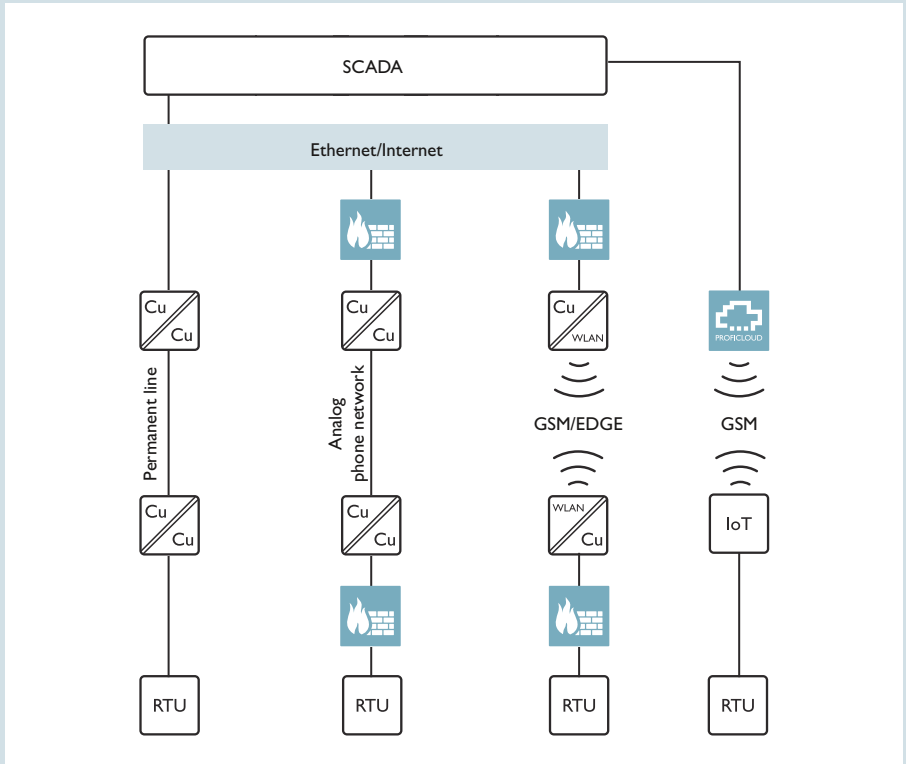





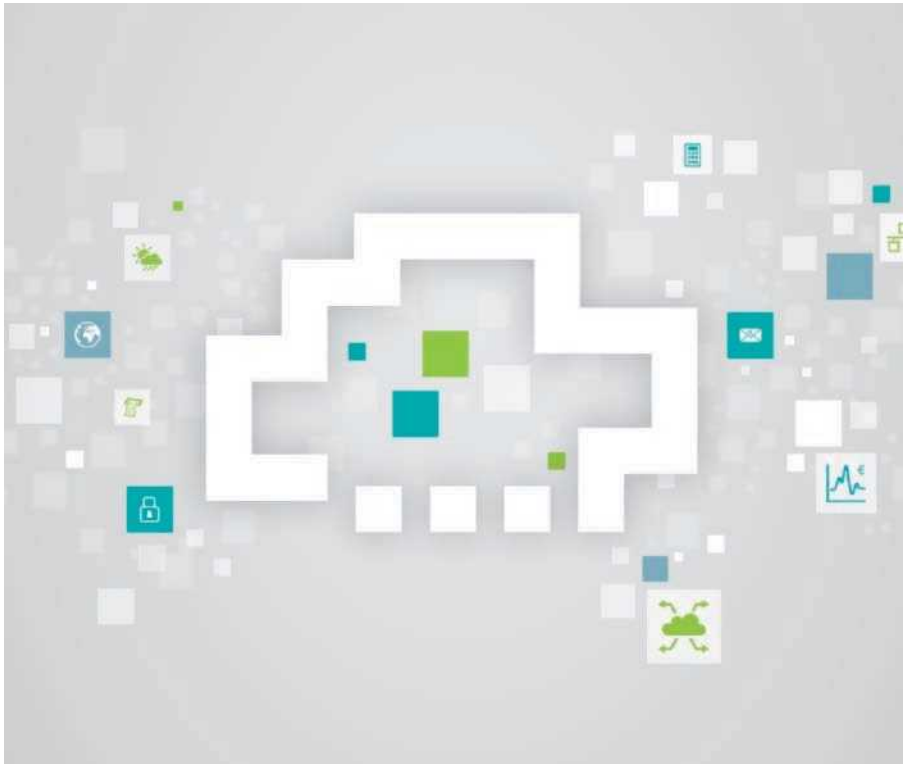









## Direct connection to the cloud

The Cloud IoT Gateway connects new and existing systems to the Internet of Things without any further engineering effort. Thanks to simple process connection using protocols such as Modbus/TCP, sensor and process data can be collected, processed, and monitored in the PROFICLOUD. This data can be used, for example, for machine monitoring or data analysis.













## Cloud IoT Gateway, SHDSL extender, modem, and router

Cloud IoT Gateway	Two-wire line SHDSL extender	Public telephone network ADSL modem/router	Mobile router GPRS/EDGE/UMTS/HSPA/LTE	Security router
 	 	 	 	 
<b>CLOUD IOT GATEWAY</b> <b>1031235</b>	<b>TC EXTENDER ...</b> ...6004 ETH-2S <b>2702255</b> ...4001 ETH-1S <b>2702253</b> ...2001 ETH-2S <b>2702409</b>	<b>TC DSL ROUTER ...</b> ...X400 A/B <b>2902709</b> ...X500 A/B <b>2902710</b>	<b>PSI-MODEM-GSM/ETH</b> <b>2313355</b>  <b>TC ROUTER ...</b> ...3002T-4G <b>2702528</b> ...3002T-3G <b>2702529</b> ...2002T-4G <b>2702530</b> ...2002T-3G <b>2702531</b>	<b>FL MGuard ...</b> ...RS2000 TX/TX VPN <b>2700642</b> ...RS4000 TX/TX VPN <b>2200515</b> ...RS2005 TX VPN <b>2701875</b> ...RS4004 TX/DTX <b>2701876</b>
 Web code: <b>#1898</b>	 Web code: <b>#0943</b>	 Web code: <b>#1503</b>	 Web code: <b>#1381</b>	 Web code: <b>#0101</b>
<ul style="list-style-type: none"> <li>Connects new and existing systems to the Internet of Things without interfering with the automation logic</li> <li>Collects and processes sensor and process data, and transmits this to the PROFICLOUD</li> </ul>	<ul style="list-style-type: none"> <li>Distances of up to 20 km</li> <li>Transmission speed of up to 30 Mbps</li> <li>Integrated log book for line monitoring</li> <li>Plug and Play startup</li> <li>Point-to-point, line, and ring topologies</li> <li>Integrated log book for device/path monitoring</li> <li>Redundancy structures possible</li> </ul>	<ul style="list-style-type: none"> <li>Can be used worldwide, thanks to Annex A/B/J support</li> <li>Integrated firewall</li> </ul> <p>TC DSL ROUTER X500 A/B:</p> <ul style="list-style-type: none"> <li>VPN tunneling (IPsec, OpenVPN)</li> <li>Serial device server for 10/100Base-T(X) with RS-232</li> </ul>	<ul style="list-style-type: none"> <li>Firewall and VPN (IPsec/OpenVPN)</li> <li>3G and 2G fallback</li> <li>Worldwide broadband connection via the mobile phone network</li> <li>Data rate of up to 150 Mbps</li> <li>Temperature range: -40°C ... +70°C</li> </ul>	<ul style="list-style-type: none"> <li>1:1 NAT, NAT, port forwarding, standard routing, stateful inspection</li> <li>Firewall, separate input/output rules, up to 99 Mbps of data throughput</li> <li>-25°C ... +65°C, slot for SD card</li> </ul>
–	ATEX, UL	G3	UL , G3	–

## Surge protection and Ethernet isolator

	SHDSL surge protection	Telecommunications surge protection	Surge protection for coaxial lines	Ethernet isolator
				 
Type Order No.	DT-TELE-SHDSL <b>2801593</b>   Web code: <b>#0145</b>	DT-TELE-RJ45 <b>2882925</b>   Web code: <b>#0145</b>	CSMA-LAMBDA/4-2.0-BS-SET <b>2800491</b>   Web code: <b>#0146</b>	FL ISOLATOR ... ...1000-RJ/RJ <b>2313915</b> ...100-RJ/RJ <b>2313931</b> ...100-RJ/SC <b>2313928</b>   Web code: <b>#1579</b>
Description	DATATRAB, surge protection for two signal pairs of the SHDSL telecommunications interface	DATATRAB, surge protection for two signal wire pairs of the DSL telecommunications interface	Surge protection for UTMSS and quad-band GSM antennas, with SMA connector and SMA coupling	Network isolator for electrical isolation up to 4 kV, 2 x RJ45 socket, for transmission speeds up to 1 Gbps
Approvals	–	–	–	UL

Detailed information and additional approvals can be found at: [phoenixcontact.com/products](http://phoenixcontact.com/products)

# Remote control solutions and wireless technology

## Create your own individual remote control system

For a long time, remote control was synonymous with the use of expensive, self-contained systems. In particular, this meant that small external stations were often not monitored. With Phoenix Contact's flexible remote control system, you can now create a customized and inexpensive solution even for small stations. You can decide which functions you require.

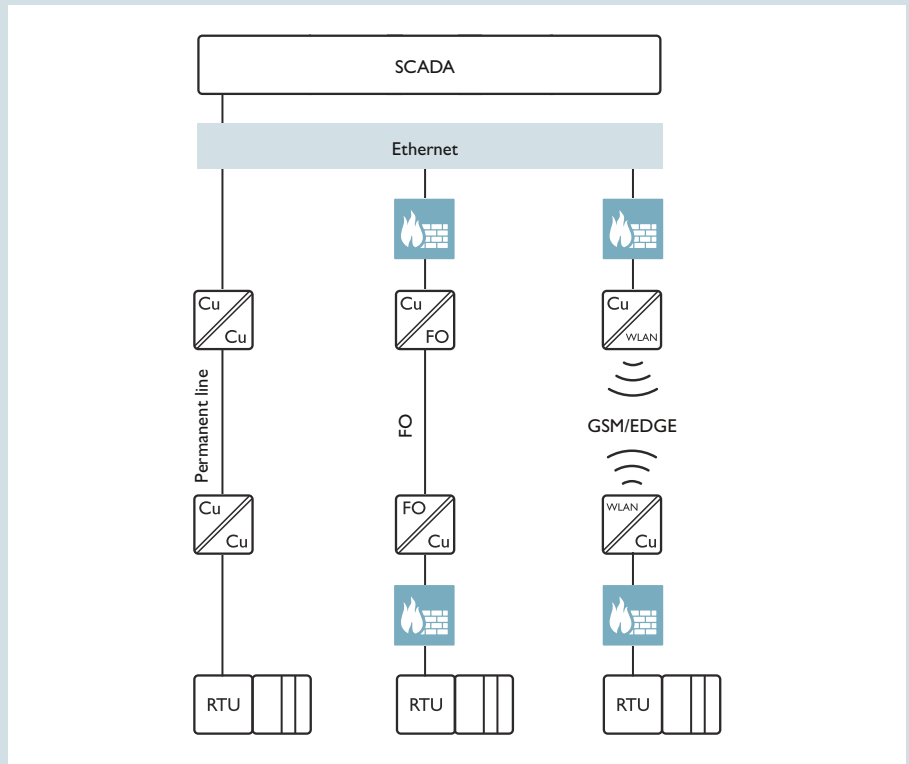







## Flexible communication technologies

Thanks to special protocols, you can transmit process data securely over wide area networks, even with low bandwidth and with poor transmission quality. Phoenix Contact offers remote control solutions for virtually all telecommunications networks, such as:





- Company-owned two-wire lines using SHDSL
- Wireless networks such as Bluetooth and Trusted Wireless
- Public phone or mobile networks such as ADSL, GPRS/EDGE (2G), UMTS/HSPA (3G) and LTE (4G)



## TC MOBILE I/O and remote control software

				
		<b>Remote control station</b>	<b>Remote control software</b>	<b>Remote control software</b>
Type	Order No.	TC MOBILE I/O X300 <b>2903807</b> TC MOBILE I/O X300 AC <b>2903808</b>	RESY-DATA-A LIC <b>2876847</b> RESY+ <b>2400295</b>	AX ODP SERVER ... ...10 FU <b>2700393</b> ...100 FU <b>2700402</b> ...250 FU <b>2700406</b>
		 Web code: <b>#1629</b>	 Web code: <b>#2021</b>	 Web code: <b>#2022</b>
Description		The compact TC Mobile I/O X300 GPRS remote control system for mobile networks enables the remote monitoring of analog and digital values and switching of relay outputs. Communication takes place via ODP protocol. An alert is sent via SMS in the event of voltage failure.	Resy+ enables you to enhance our controllers to create a remote control station. Configure your remote control station independently and start it up with just a few clicks. Resy+ enables communication via IEC 60870-5-101/104, ODP or Modbus/RTU/TCF.	The ODP server enables open communication between the remote control station and the control system. ODP transmits online values and historical data via the mobile network. When saving the process data in the event of a fault, a time stamp is applied to ensure that data is re-sent at a later time.
Approvals		ATEX	–	–

## I/O terminals and controllers

 Web code: <b>#1159</b>		
	<b>I/O terminals</b>	<b>Controllers</b>
Type	Order No.	
	IB IL 24 DI 4-ME <b>2863928</b> IB IL 24 DI 16-PAC <b>2861250</b> IB IL 24 DI 32/HD-PAC <sup>1</sup> <b>2862835</b> IB IL 24 DO 2-PAC <sup>1</sup> <b>2861470</b> IB IL 24 DO 4-PAC <b>2861276</b> IB IL AO 2/SF-PAC <b>2863083</b>	ILC 131 ETH <b>2700973</b> ILC 151 ETH <b>2700974</b> ILC 171 ETH 2TX <b>2700975</b> ILC 191 ETH 2TX <b>2700976</b> ILC 131 ETH/XC <b>2701034</b> ILC 151 ETH/XC <b>2701141</b>
	 Web code: <b>#2017</b>	 Web code: <b>#1159</b>
Description	Digital and analog Inline input and output terminals cover all typical applications in the field of remote control technology. The I/O devices are connected by a simple or an extended Inline connector, depending on the number of channels. Multi-conductor connection technology is used in both cases. The Inline terminals are marked using hinged marking fields.	The remote controller from Phoenix Contact acquires and temporarily stores data, sends alarms, and controls the connected process. The controller can be expanded to achieve various performance classes and supports highly modular expansion by means of digital and analog inputs and outputs, thus providing the optimum hardware solution for your remote control technology tasks.
Approvals	UL <sup>1</sup> GL, UL	ATEX, GL, UL

Detailed information and additional approvals can be found at: [phoenixcontact.com/products](http://phoenixcontact.com/products)

# Remote control solutions and wireless technology

## Solutions for the transmission of I/O and serial signals

### Remote control with wireless systems

With wireless systems, you simply record measuring data and system information from distant or hard-to-access areas and transfer it to central points.

For remote control technology, this provides a reliable, cost-efficient alternative to new cable paths. This is particularly true during the installation of new system components or the replacement of defective communication cables. The wireless modules have various interfaces and act as a gateway between local sensors and actuators of the process station and the control center.

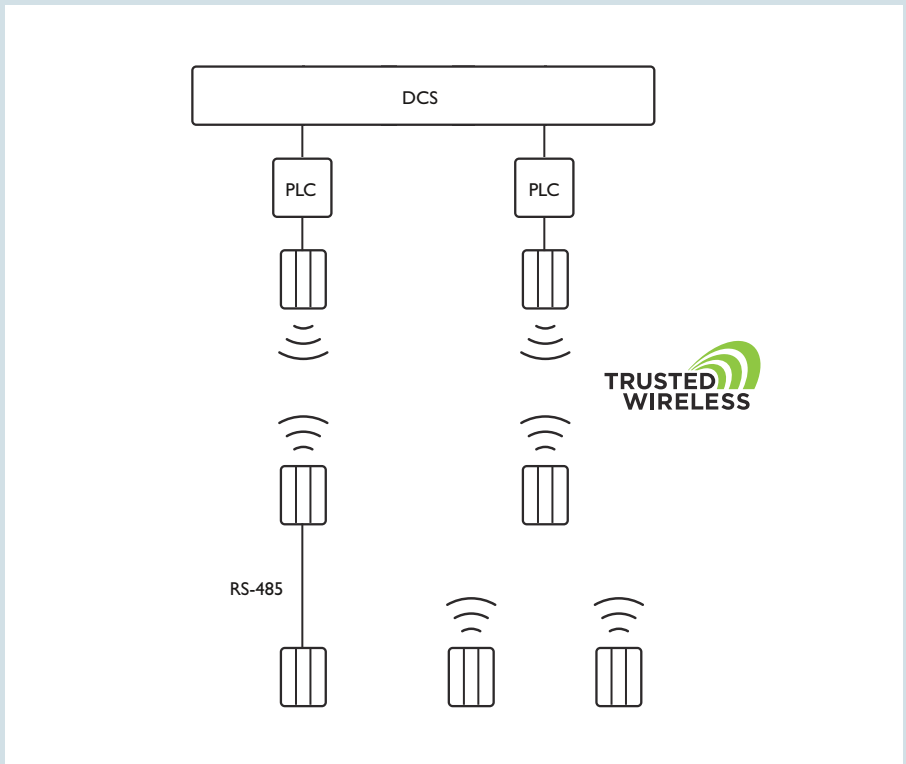

## Trusted Wireless 2.0

Trusted Wireless technology is specifically designed for the reliable transmission of data and signals over long distances. The new Version 2.0 offers adjustable data rates, encryption, extended diagnostics, and parallel operation of multiple networks. Distances in the kilometer range can be achieved with the 2.4 GHz system and even greater distances can be covered with the 868 MHz system. Longer transmission paths are covered using repeater stations.

### The Radioline system – Easy signal distribution with I/O mapping

Radioline is the Phoenix Contact transmission system for extended systems and networks with up to 250 stations. Special features include extremely easy assignment of inputs and outputs by simply turning the thumbwheel – without any programming.

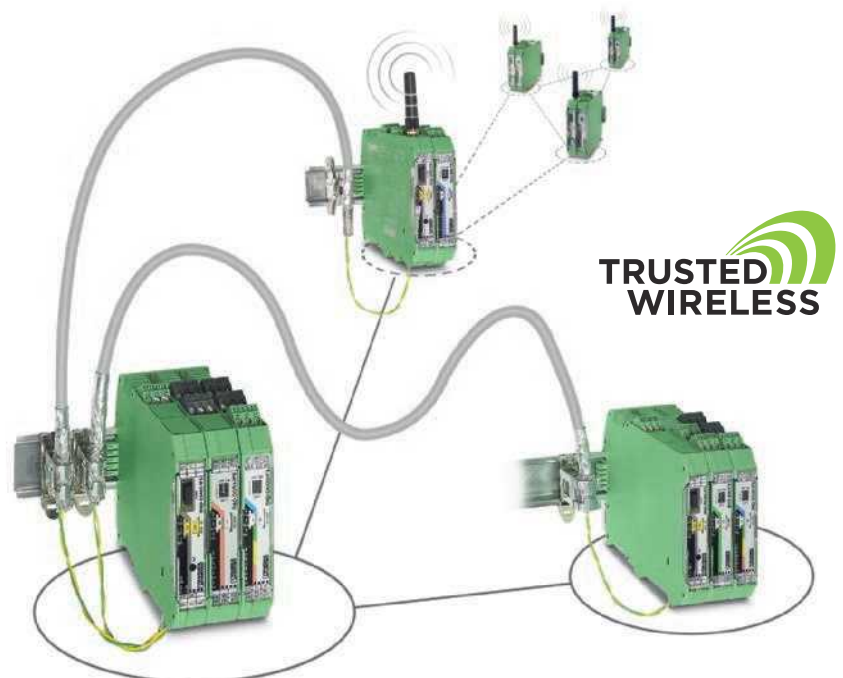

## Radioline products

**i** Web code: #1927



**Front modules**

**I/O modules**

**Accessories**

Type	Order No.	Europe 868 MHz: RAD-868-IFS	2904909	Four digital inputs: RAD-DI4-IFS	2901535	RF band 3: RAD-CONF-RF3	2902814
		America, Canada 900 MHz: RAD-900-IFS	2901540	Eight digital inputs: RAD-DI8-IFS	2901539	RF band 5: RAD-CONF-RF5	2902815
		Australia 900 MHz: RAD-900-IFS-AU	2702878	Four analog inputs: RAD-AI4-IFS	2901537	RF band 7: RAD-CONF-RF7	2902816
		Global 2400 MHz: RAD-2400-IFS	2901541	Four Pt 100 inputs: RAD-PT100-4-IFS	2904035	Freely configurable: RAD-MEMORY	2902828
		Global 2400 MHz: RAD-2400-IFS-JP	2702863	Four digital outputs: RAD-DOR4-IFS	2901536	Configuration cable: RAD-CABLE-USB	2903447
				Eight digital outputs: RAD-DO8-IFS	2902811	SKS 8-SNS35	3062786
				Four analog outputs: RAD-AO4-IFS	2901538	Configuration stick 868 MHz: RAD-868-CONF-RF1	2702197
				Mixed module 2DI/2DO, 1AI/1AO: RAD-DAIO6-IFS	2901533	Configuration stick 900 MHz: RAD-900-CONF-RF1	2702122
Approvals		ATEX, IECEx, G3, UL		ATEX, IECEx, G3, UL		-	

Detailed information and additional approvals can be found at: [phoenixcontact.com/products](http://phoenixcontact.com/products)

## One device – A wide range of applications

Radioline transmits I/O signals as well as serial data and is therefore very versatile. Trusted Wireless technology also ensures reliable transmission in harsh industrial environments, whatever the protocol type. The Radioline function blocks for PC Worx, STEP 7 and TIA Portal enable easy I/O integration in the control level.

### Radioline features:

- Adjustable data rates for the wireless interface
- Easy module replacement, even during operation (hot-swap capability)
- Channel-to-channel electrical isolation
- Extended temperature range: -40°C to +70°C

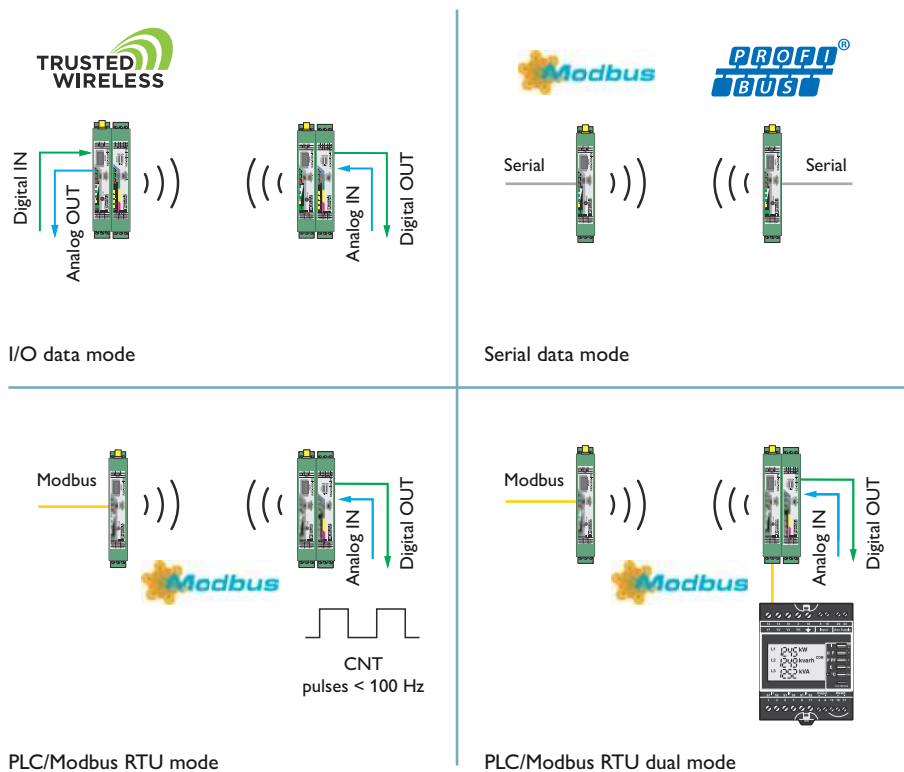

# Stainless steel empty enclosure for the Ex area

The CLIPSAFE stainless steel enclosures provide comprehensive protection for your applications in industrial environments and in process technology areas.

The housing range consists of 140 standardized housings in sizes up to 1000 x 1000 x 300 mm. Custom dimensions and surface treatments are available on request. The housings have ATEX and IEC Ex approval and are designed for a temperature range from -55°C to +135°C. The door can be opened 135°. The stop is interchangeable. Various different door and cover versions are also available.



## Empty Ex enclosures

Select the right stainless steel housing for your application. The housings feature a corresponding component approval in accordance with IECEx and ATEX.



## Empty Ex enclosures processed according to customer specifications

We can customize the housings with threads, bore holes and rectangular cutouts according to your specifications, taking Ex standards from ATEX and IECEx into consideration.



## Your advantages

- ✓ Innovative product range of high-quality stainless steel housings as the basis for individual terminal boxes
- ✓ Reduced assembly and approval effort, thanks to ready-equipped junction boxes
- ✓ Individually equipped with all approved terminal blocks from the CLIPLINE complete system
- ✓ Can be assembled with approved controller and interface components on request
- ✓ Professional customer support and short delivery times, thanks to our worldwide sales network



**Ex terminal boxes equipped according to customer specifications**

If desired, you can obtain the CLIPSAFE empty enclosure completely equipped with terminal blocks and cable glands.



**Ex control boxes in accordance with customer specifications**

Custom control boxes with electronic components are available on request.



**Cable glands for the Ex area**

Cable glands are available in Ex e/Ex i designs and meet the requirements of both ATEX and IECEx directives.

# Stainless steel enclosure for the Ex area

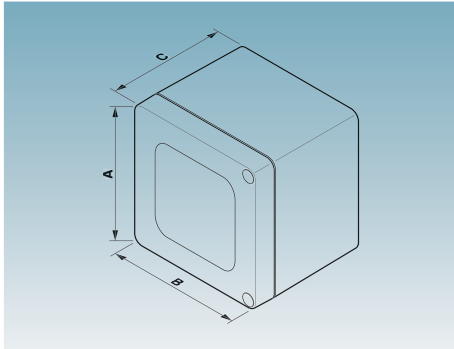

## Design data and equipment tables

CAD drawings in STEP, IGES, and DXF format can be downloaded directly from the website in the product area for the respective empty enclosure.

## Comprehensive product range

The housings are available as door or cover versions in nine different depths and sizes up to 1000 mm x 1000 mm x 300 mm. The robust housings made from up to 2 mm thick, high-grade 1.4404 (V4A/AISI 316L) or 1.4301 (V2A/AISI 304) stainless steel are ideal for use under extreme conditions.

## Flexible door stop

The door stop can be easily changed according to your individual requirements or the installation situation. The 135° opening angle of the door guarantees comfortable work during maintenance and servicing. The special door and cover seal guarantees a reliable seal even after it has been opened multiple times.

## CLIPSAFE – Innovative enclosure concept

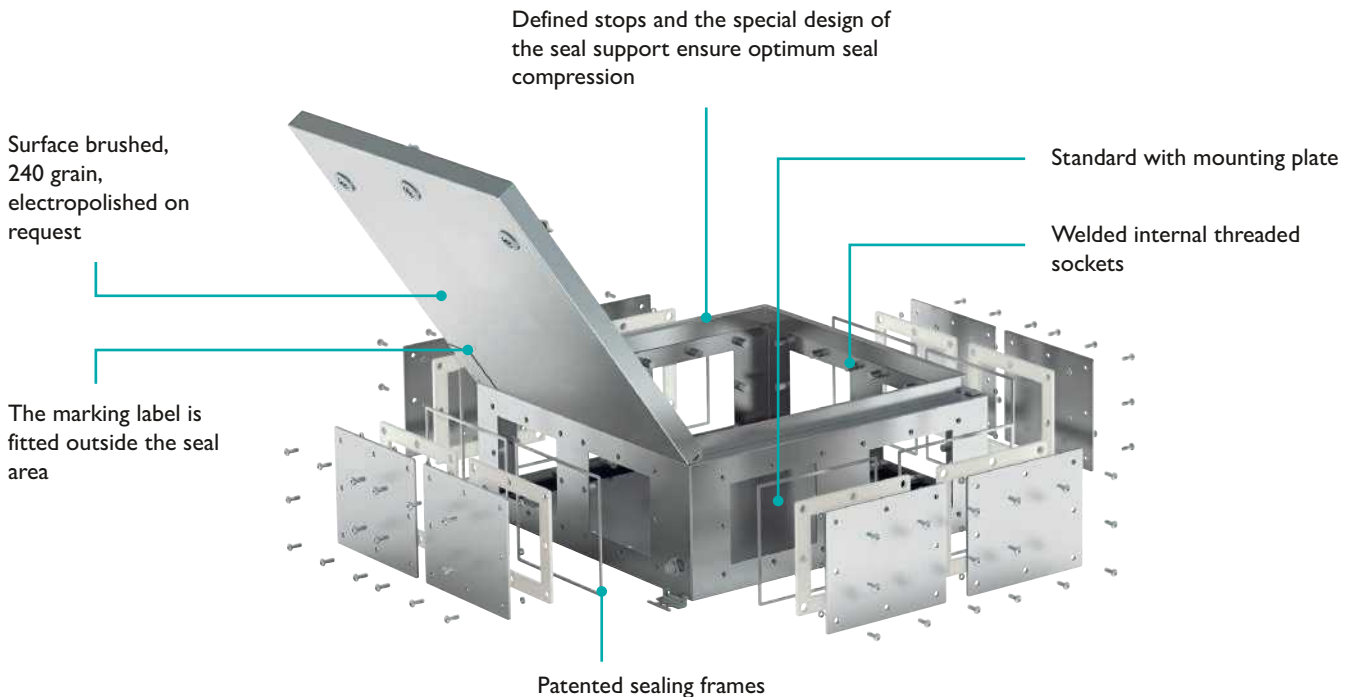





### Flexible wall fastening

The mounting brackets that are supplied as standard can be flexibly adapted to the installation situation. Welded-on mounting brackets are available on request.



### Individual equipping with flange plates

The junction boxes and empty enclosures can be equipped with flange plates on up to four sides starting from a depth of 160 mm. The flange plates are equipped with patented protective sealing frames and with captive mounting screws.



### Protection against moisture and dirt

A drainage channel integrated in the housing design prevents the ingress of moisture and dirt when opened. The flat seal edge protects against injury during installation and when carrying out maintenance and servicing.

## Customer-specific solutions

Please use the inquiry forms on the website to request a custom terminal box and housing solution. You can easily describe your requirements using the forms. We will then prepare an individual quote based on the information provided.

Just enter the web code into the search field on our website.

 Web code: #0140



Detailed information and additional approvals can be found at:  
[phoenixcontact.com/products](http://phoenixcontact.com/products)

<hr/>		
<b>A</b>		
Analog input	60 f., 66 f., 74 f., 90 f.	
Analog output	60 f., 68 f., 90 f.	
<hr/>		
<b>B</b>		
Box PCs	20 f.	
Bus couplers	60 f.	
<hr/>		
<b>C</b>		
Cable binders	52 f.	
Cable ducts	52 f.	
Cable markers	48 f.	
Com server	24, 78, 109 ff.	
Connection technology	34 ff.	
Control cabinet for the Ex area	118 ff.	
Converter	66 f., 74 f.	
Coupling relays	58 f., 70 ff.	
Crimping tools	53	
Cutting tools	52 f.	
Cyber security	25, 113	
<hr/>		
<b>D</b>		
Device markers	48 f.	
Digital input	58 ff., 70 f.	
Digital output	58 ff., 72 f.	
DSL	110 ff.	
<hr/>		
<b>E</b>		
Electrical isolation	58 f., 62 ff. 86 ff., 113, 117	
EMpro	80 f.	
Energy measurement	80 f.	
Ethernet	24 f., 77, 111 ff.	
Ethernet extender	111 ff.	
Ethernet patch panel	25, 111	
Ex i I/Os	60 f., 66 ff.	
Ex relays	58 f.	
<hr/>		
<b>F</b>		
Feed-through terminal blocks	40 ff.	
Fieldbus	98 ff.	
Force-guided coupling relays	73	
Function terminals	45	
Fuse plug	31, 44 f.	
Fuse terminal blocks	31, 44 f.	
<hr/>		
<b>H</b>		
HART	76 ff.	
HART communication	76 ff.	
HART Gateway	76	
HART MUX	78	
Head transmitters	66 f., 75	
HMI	20 f.	
<hr/>		
<b>I</b>		
I/O system	17, 60 f.	
I/O terminals	60 f., 115	
Industrial Ethernet	18 ff.	
Industrial PCs	20 f.	
Industrial security	25	
Industrial Wireless	25, 76 f., 98 ff., 106 ff.	
Inline	60 f., 66 ff., 115	
<hr/>		
IPC	20 f.	
IPsec	113	
Isolator	61	
Isolator	66 f., 113	
<hr/>		
<b>K</b>		
Knife disconnect terminal blocks	42 f.	
<hr/>		
<b>L</b>		
Labels	48 ff.	
Labels	48 ff.	
Lightning protection	62 ff.	
<hr/>		
<b>M</b>		
MACX	66 ff., 78, 92 f.	
Managed Switches	22 f.	
Marking	48 ff.	
Marking	48 ff.	
Marshaling panel	36 f.	
Marshaling patchboard	38 f.	
Marshaling terminal	34 ff.	
Measuring transducers	66 f., 74 f.	
Media converters	24, 111	
MINI	58 f., 67, 69, 71, 75, 90 f., 94 f.	
Modbus Gateway	79	
Motor control	82 f.	
Motor management	82 f.	
Motor monitoring	82 f.	
Mounting material	52 f.	
Multiplexers	77 f.	
<hr/>		
<b>N</b>		
Namur	60 f., 70 f.	
Namur input	61, 70 ff., 100 f.	
Namur isolators	70 f.	
NAT	25, 112	
Network technology	22 ff., 110 ff.	
<hr/>		
<b>O</b>		
ODP protocol	115	
ODP remote control station	115	
ODP server	115	
Output isolator	66 ff.	
<hr/>		
<b>P</b>		
PA muxers	100 f.	
Panel PCs	20 f.	
Patch panels	25	
Performance measurement	80 ff.	
PE terminal blocks	41, 45, 47	
Planning software	54 f.	
PLC interface	71, 73, 86 ff.	
PLClogic logic relay system	71, 73	
Potential distributors	36 f.	
Power supplies	26 ff.	
Power supply doubler	66 f.	
PROFIBUS	61, 79, 100 ff., 108 f.	
PROFIBUS DP	79	
PROFIBUS PA gateway	100 ff.	
PROFINET gateway	77	
Protective conductor terminal blocks	40 f.	
Protective hoses	53	
<hr/>		
<b>R</b>		
Radioline	100 f., 116 f.	
Relay for zone 2	73	
Remote control	106 ff.	
Repeater power supplies	66 f.	
RIFLINE complete	73	
RS232 interface	108 f.	
RS422 interface	109	
RS485 interface	81, 109	
RTD	61, 74 f.	
<hr/>		
<b>S</b>		
Safety relay modules	58 ff., 94 f.	
SCADA	12 f.	
Security	25, 113	
Serial device server	111, 113	
Services	54 f., 118 ff.	
SHDSL	108 ff.	
Shield clamps	52	
Shrink sleeves	51	
Signal conditioner	66 ff. 90 ff.	
Signal connection	56 ff.	
Signal terminal blocks	66 ff.	
Solenoid driver	101	
Stripping tools	53	
Surge protection	29, 62 ff., 105, 113	
Switches	22 f.	
System cabling	84 ff.	
<hr/>		
<b>T</b>		
TC-MOBILE I/O C300	115	
TC	111 ff.	
TC router	113	
Temperature input	61, 74 f.	
Terminal markers	48 f.	
Test disconnect terminal blocks	46 f.	
Thermo input	61, 74 f.	
Tools	52 f.	
Transformer terminal blocks	46 f.	
Trusted Wireless	100 ff., 116 f.	
<hr/>		
<b>U</b>		
Unmanaged Switches	22 f.	
<hr/>		
<b>W</b>		
Warning labels	51	
Wireless	25, 76 f., 109, 113, 115	
Wireless	76, 100 f., 108 f., 116 f.	
Wireless HART	76 f.	
Wireless routers	113	
WLAN	25, 109, 113, 115	
<hr/>		
<b>1, 2, 3...</b>		
2.4 GHz	108 f., 116 f.	
868 MHz	108 f., 116 f.	
900 MHz	108 f., 116 f.	



## In dialog with customers and partners worldwide

Phoenix Contact is a globally present, Germany-based market leader. Our group is synonym for future-oriented components, systems, and solutions in the fields of electrical engineering, electronics, and automation. A global network across more than 100 countries, and 16,500 employees ensure a close proximity to our customers, which we believe is particularly important.

The wide variety of our innovative products makes it easy for our customers to find future-oriented solutions for different applications and industries. We especially focus on the fields of energy, infrastructure, process and factory automation.



You will find our complete product range at:  
[phoenixcontact.com](http://phoenixcontact.com)

PHOENIX CONTACT GmbH & Co. KG  
Flachmarktstraße 8  
32825 Blomberg, Germany  
Phone: +49 52 35 3-00  
Fax: +49 52 35 3-4 12 00  
E-mail: [info@phoenixcontact.com](mailto:info@phoenixcontact.com)  
[phoenixcontact.com](http://phoenixcontact.com)